

- ALL 304 STAINLESS STEEL CONSTRUCTION
- ALL 304 STAINLESS STEEL SOLID COMPONENTS

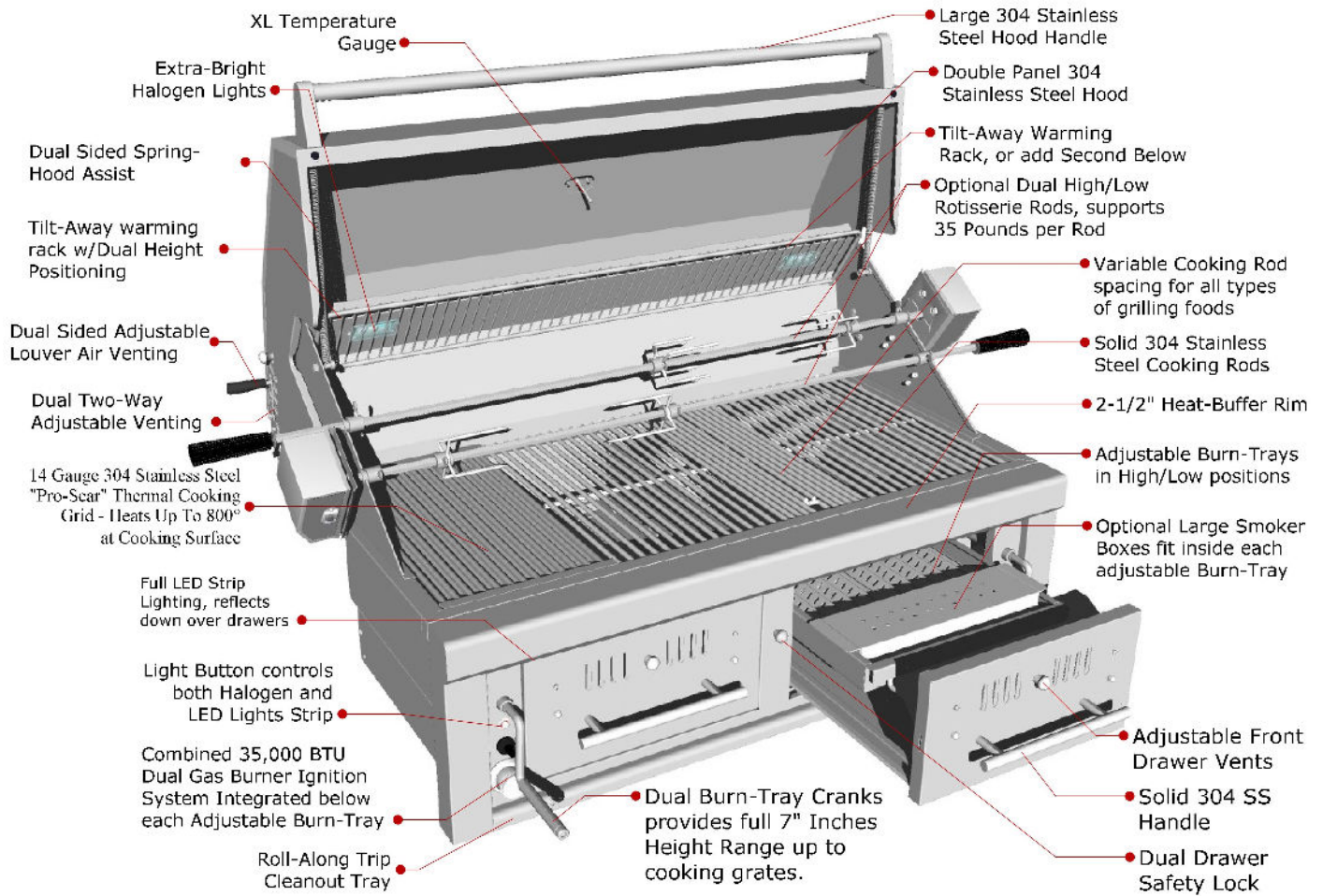

**Read all instructions before you operate your grill.  
SAVE THIS MANUAL!**

## INDEX DIRECTORY

### Grill Safety and Warnings

Grill Safety and Warnings-----	3
Clearances and Placement-----	4
Grill Specification Guide-----	5
Island and Gas Setup -----	6
Step by Step Guide -----	7
Lighting the Grill -----	8
Using your Grill -----	10
Grill Parts Diagram -----	11
Grill Gas Conversion-----	13
Q & A Trouble Shooting -----	17
Grill Warranty -----	18



## How to Obtain Service

### Before you call

Have you read through this product manual?

Have you read and understood the Product Warranty on the last page of this manual?

Please make sure you have the following information:

**Model Number | Date of Purchase | Invoice Number.** (The Invoice Number can be found on the packing slip when your grill is delivered, it is 5 digits numeric number) Be sure to keep that for your records and any future warranty claims.

For warranty service, contact SUNSTONE Customer Service Department at (888)-934-9449 or email

[service@sunstonemetalproducts.com](mailto:service@sunstonemetalproducts.com), we will response within 1-2 business days Monday to Thursday.

Must keep copy of your sales slip for proof of purchase to receive any warranty on product. Register your Warranty at [www.sunstonemetalproducts.com](http://www.sunstonemetalproducts.com) and receive special perks and bonuses.

YOU'RE NAME \_\_\_\_\_

DATE OF PURCHASE \_\_\_\_\_

ADDRESS \_\_\_\_\_

INVOICE NUMBER \_\_\_\_\_

## GRILL SAFTY AND WARNINGS

 **ATTENTION:** Improper installation, adjustment, alteration, service or maintenance can cause injury or property damage. Read the installation, operating and maintenance instructions thoroughly before installing or servicing this equipment.

 **ATTENTION:** Indicates a potentially hazardous situation which, if not avoided, may result in minor or moderate personal injury, or property damage.

 **WARNING:** Indicates an imminently hazardous situation which, if not avoided, will result in death or serious injury.

 **EXPLOSION:** Indicates an imminently hazardous situation which, if not avoided, will result in possible explosion and cause death or serious injury.

 **BODILY INJURY:** Indicates a potentially hazardous situation which, if not avoided, may result in minor or moderate personal injury, or property damage.

 **HOT SURFACE:** Indicates an imminently hazardous hot surface which, if not avoided, will result in serious burn or injury.

 **OPEN FLAME:** Indicates an imminently hazardous situation which, if not avoided, will result in death or serious injury.

 Do not add charcoal starter fluid or charcoal impregnated with charcoal lighter fluid to hot or warm coals. Cap starter fluid after using and place a safe distance away from the grill.

 Do not use gasoline, alcohol, or other highly volatile fluids to ignite charcoal.

 Do not leave infants, children, or pets unattended near the grill.

 Do not remove ashes until all coals are completely burned out and are fully extinguished.

 Do not wear clothing with loose flowing sleeves while lighting or using the grill.

 Do not use this charcoal grill in high winds. Or with back of grill facing wind direction.

 Do not store combustible materials (charcoal, Firelighters, etc.) in the storage area under the ash pan while using the grill.

 Do Not Close the Lid of the Grill while Lighting the Charcoal with Gas Burners.

 Barbecue mitts or hot pads should always be used to protect hands while barbecuing, opening the fire door, or adjusting the dual draft vents.

 Use proper barbecue tools with long, heat resistant handles.

 Never touch the cooking grates while charcoal Or gas burners are lit to see if it is hot.

 Burning charcoal inside can kill you. It gives off carbon monoxide, which has no odor. NEVER burn charcoal inside homes, vehicles, or tents.

 To extinguish coals, close the hood, fire door, and dual draft vents. Do not use water.

 To control flare ups, close the hood and, if necessary, the fire door and dual draft vents.

 Gas Ignition Burners are for Igniting Charcoal or Wood Logs ONLY, do not run continually.

 Handle and store hot electric starters carefully. Keep electrical cords away from the hot surfaces of the grill.

## CLEARANCES AND PLACEMENT



**ATTENTION:** Do Not Build Enclosure around Firebox of Grill, Grill Free-Hangs from Counter Top, DO Not Build Shelf below Grill of any kind. **Must have Minimum of Two Vents for this Grill, for Natural Gas place in High Position, and for Liquid Propane place in Low Position.**

Your grill is **SELF-RIMMING**, meaning the lip of grill rests on top of the counter edge around the cut-out with the front of grill which is Free-Hanging from counter top. Because of this, there is No Need for any Trim-Kit like with many other grill in the market.

- Maintain 24" Clearance from any Combustible Materials in ANY direction of Grill.
- If any combustible materials within 24" distance, must have Heat Barrier like Grill Jacket, or other Non-Combustible type like Bricks, Hardy Board, Metal.
- Orient the grill so the Prevailing winds are not blowing into the rear or side of grill.

### **Minimum Distances**

From Back Cut-Out Grill Line to Wall	6-1/2" Min. Clearance
From Counter to Outdoor Vent Hood	36" Min. Clearance
From Floor to Counter Top	34" Min. Clearance
From Grill to Vent Hood Width	4"-6" Min. Clearance
From Appliance to Appliance	12" Min. Clearance
From Appliance to Combustible Material	24" Min. Clearance



**ATTENTION:** Take special precaution when installing grill in open Breezy area, check the direction of Prevailing Wind, if the back of the grill is facing any oncoming wind or breeze, be sure to protect the back of the grill, and erect a partition wall, or only use grill with hood open on breezy days.

### **Windy Area**

Positioning your grill in your backyard is more often thought of how it is pleasing to the eye, but more important than this is how that it functions correctly. Unlike an indoor appliance, your grill has to combat many outside weather influences in all manner of weather related instances, most severely is Wind.

- Maintain proper Prevailing wind, grill direction – with the front of grill facing in to the wind, and the back of grill in the direct wind is blowing. If direction of wind is unclear, or difficult to combat even with preventative measures, then always grill with the hood open, and when hood is closed – always be within close proximity to grill and monitor it that it does not overheat.
- If wind or breeze is in the direction of back of grill, you must erect partition wall of 14" height so that the top of grill hood is covered by several inches. If this is not done, you must grill with hood open and or when hood is closed stand in close area to grill and monitor if the grill overheats.

# GRILL SPECIFICATION GUIDE

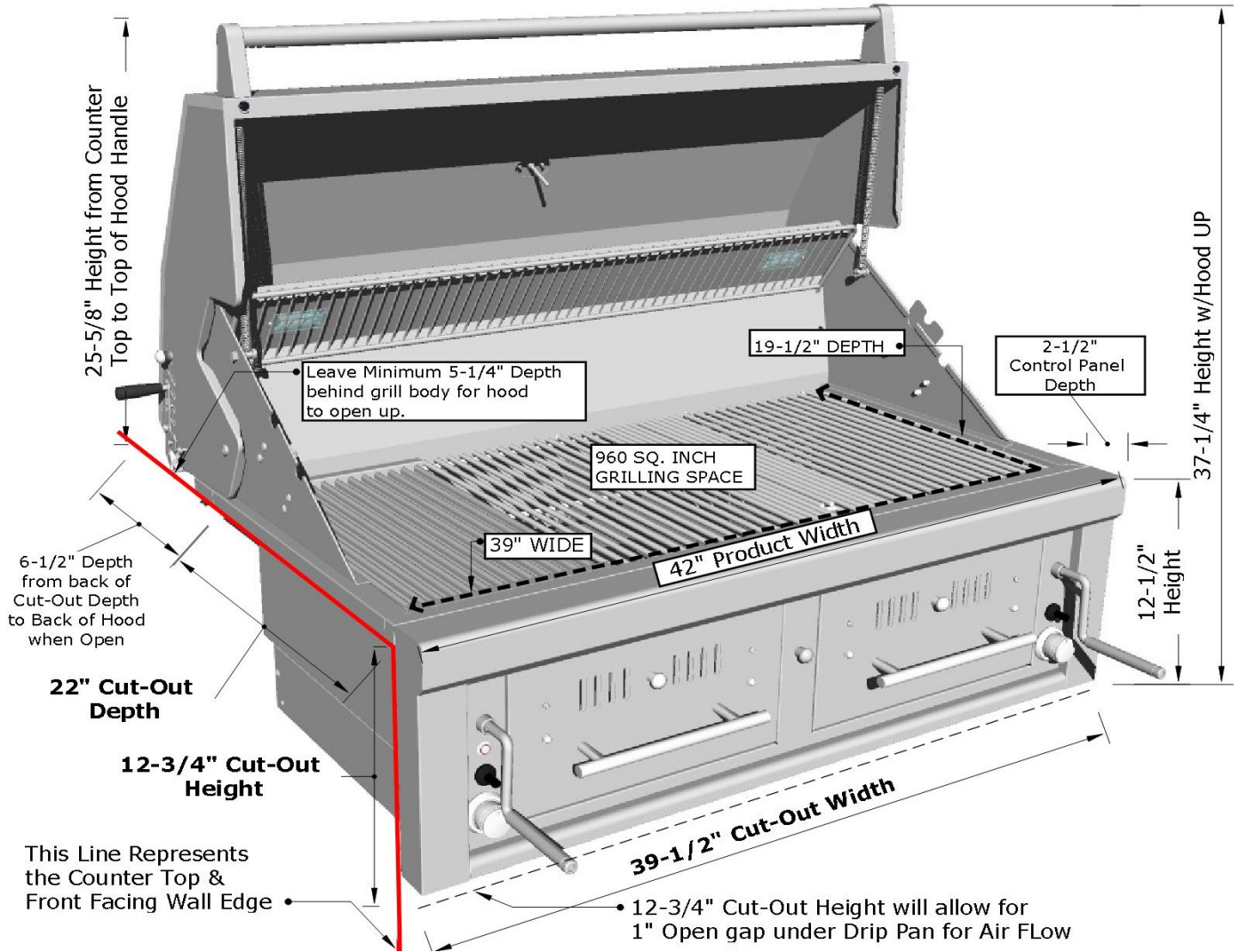

## PRODUCT DIMENSIONS

Product Size - 42"W x 27-1/8"D x 28"H  
Cut-Out Size - 39-1/2"W x 22"D x 12-3/4"H  
Product Weight – 216 LBS

## HOOD UP DIMENSIONS

Counter to Top of Hood - 25-5/8" Height  
Back Cut-Out to Back of Hood - 6-1/2" Depth  
Space behind Grill Back – 5-1/4" Depth

## HOOD DOWN DIMENSIONS

Counter to Top of Hood – 14-1/4" Height  
Front Hood Riser - 5" Height  
Space behind Grill Back – 5-1/4" Depth

## COOKING SPECIFICATIONS

Cooking Surface Size - 960 Sq. In.  
Warming Rack Size - 220 Sq. In.  
Rotisserie Rod Supporting Weight – 35 Pounds

## GAS BURNER SPECIFICATIONS

Burner Type - 304 SS Tubular  
Gas Burner BTU's - 17,500 BTU's per. Burner  
Burner Ignition Type – Piezo

## BURN TRAY SPECIFICATIONS

Burn Tray Size - 14" Width x 13-1/2" Depth  
Burn Tray Load Height - 3" Charcoal/Wood Height  
Burn Tray Height Range – 7" Adjustable Height within 1" of Cooking Grate.

## ISLAND AND GAS SETUP

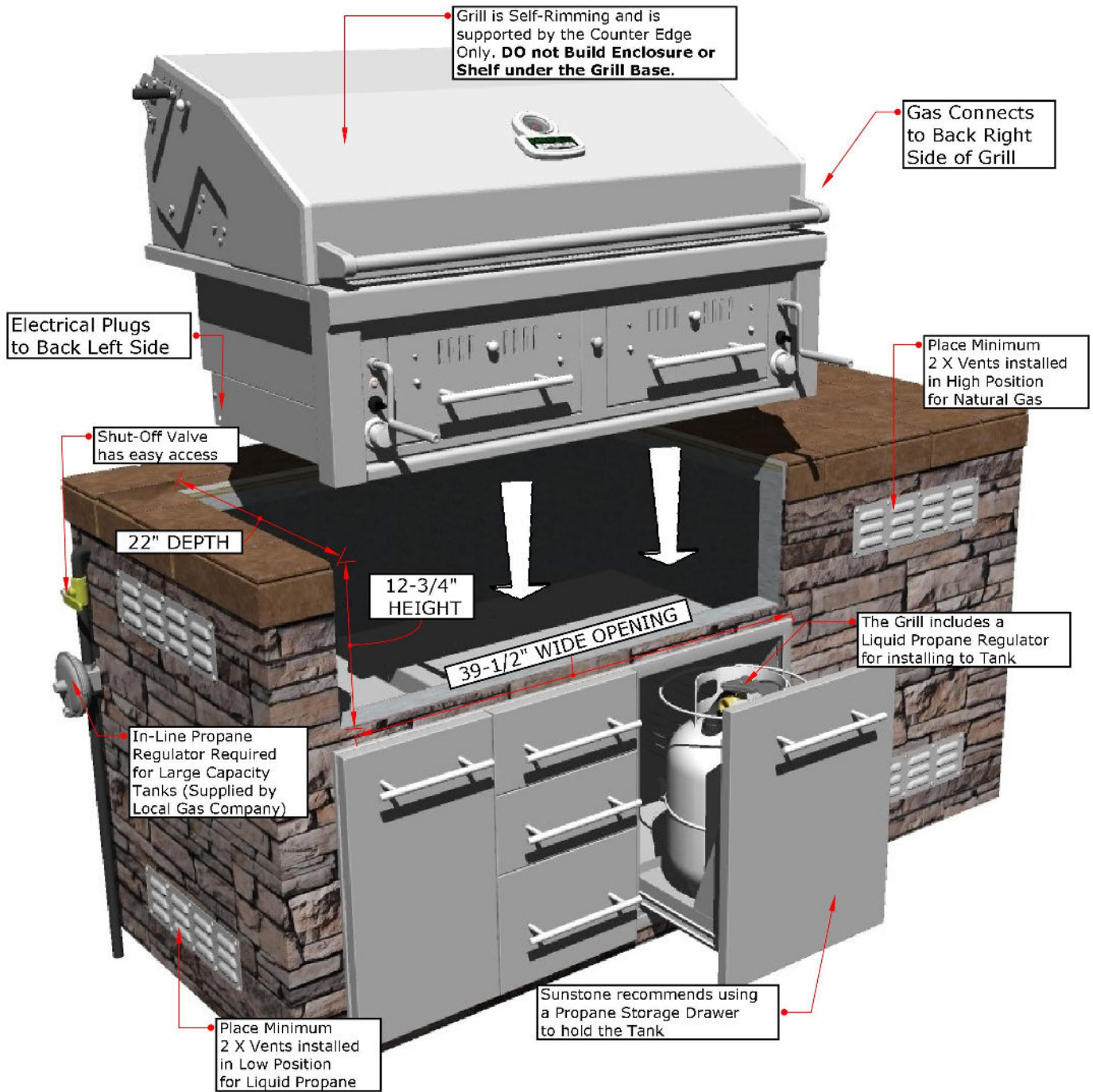

**⚠️ NOTICE:** All Gas Lines for either Liquid Propane or Natural Gas should be installed by a Licensed Professional ONLY! All Liquid Propane Installation with a Large Capacity Side Yard Tank, requires a Medium Pressure In-Line Regulator to be installed by Licensed Professional. Grill includes LP Regulator for 25 Pound Portable Tank only, if you require grill to use Natural Gas, please call our Technical Support Line and request NG-Conversion Kit for Item No. SUNCHDZ42 at 888-934-9449.

## **STEP BY STEP GUIDE**

### **1. Locate the Electrical Transformer inside Grill**

Remove the transformer from the plastic bag located in the interior of grill. Make sure the Transformer is complete, and double check the grill light plug cord is properly secured to transformer, and all wires are firmly fixed into plastic clip plug.

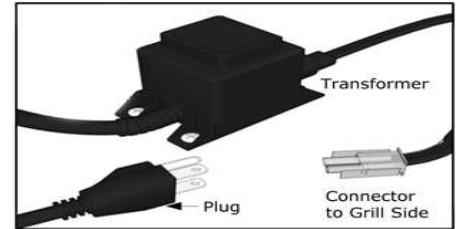

### **2. Mount Transformer to Interior Island Wall**

Using metal screws and attach the transformer to the back inner wall of your islands cabinet wall, somewhere near the already installed GFCI electrical outlet. When you plug the transformer in, double check then GFCI breaker switch, that the outlet has power.

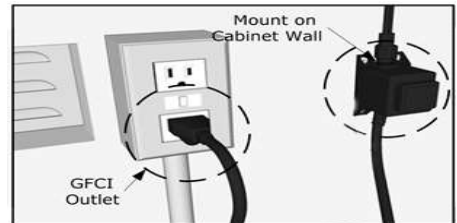

### **4. Connect Light Transformer Plug to Grill**

Locate the Light Connection on BACK-LEFT SIDE of grill. The connection clips together, to form a secure connection. Double check that all wires are tightly pushed into plug sockets, so all wires make proper connections.

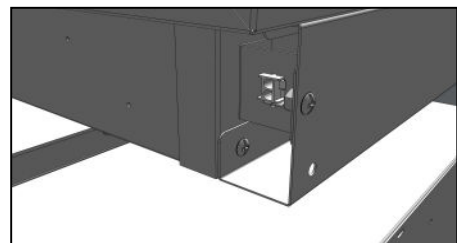

### **5. Connect Gas Line to Grill**

See the BACK-RIGHT SIDE – This is where the Gas Line will connect to the Grill. Grill is shipped as Liquid Propane ONLY and includes a LP-Regulator for portable tank. Recommendation to have a 18" Rubber or Flex hose to allow grill to be pulled out if necessary.

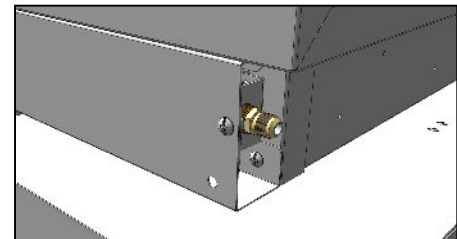

### **5. Slide Grill in Place**

Your Sunstone™ grill is specially designed with an internal built in hanger lip located at the Right, Left and Back sides. The grill lip allows it to hang by the three supported edges on the right, left and back. The front control panel requires no supporting edge; it is designed to hang down the front of your cut-out.

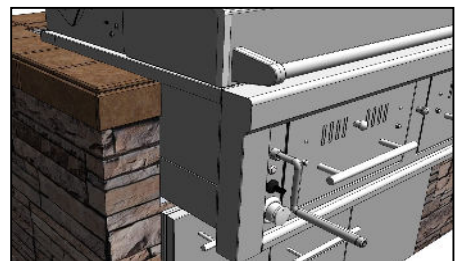

### **6. Securing in Place**

The control panel is designed to sit flush against the island face. If counter top extends beyond the islands face, creating a countertop overhang, it must be cut flush with the island face where the width of the control panel or a gap will be created exposing the forward portions of the left and right side firewalls.

### **7. Allow for Ventilation**

Your Sunstone™ grill is engineered with special vents on the back of unit, which allow proper airflow out of the back of grill. Be sure you allow a minimum of 6-1/2" behind grill for proper air ventilation and to allow hood to open properly. Push grill all the way into cut-out, so there are no gaps present to inside of island frame and grill control panel is flush against island wall.

## **LIGHTING THE GRILL**

### **⚠️ WARNING:**

When Lighting the Grill, continue to rapidly press the Black Igniter Button In & Out while allowing the Gas to Flow, if you Do Not hear a Clicking Sound, immediately turn the gas OFF – otherwise gas will continue to flow.

### **Lighting Time 3 to 5 minutes**

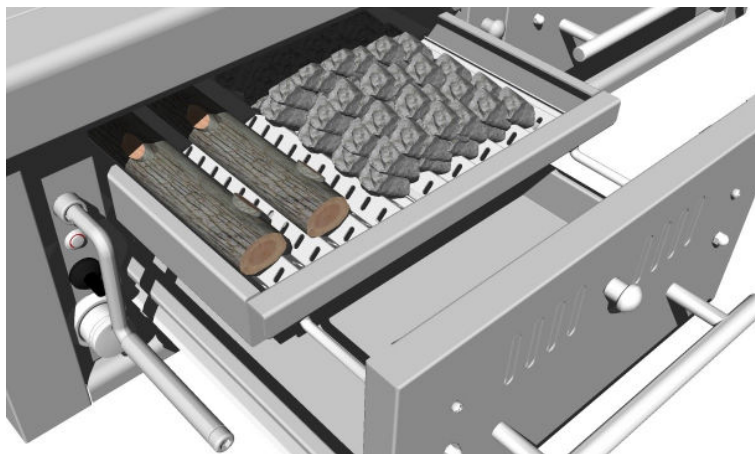

**OPEN DRAWER**

**1. Stack charcoal briquettes or wood into a pyramid-shaped pile on top of the charcoal grate or pan. We recommend using 2 pounds (approximately 30 briquettes) to start your fire, adding more as needed. – CLOSE DRAWER -**

**OPEN HOOD!**

**Ensure Burner Control Knobs are In the "OFF" position, Turn Knob to High Position.**

**2. Push in Black Push Button Igniter located above the Gas Knob on each side of grill.**

**3. You will hear a loud click as the electronic lighter produces a spark. Listen for the sound of the gas igniting and look for a flame through the cooking grids. If the burner does not light on the first try, repeat immediately.**

**4. If the burner does not light in 5 seconds then wait five minutes until the gas clears before attempting to light it again. Repeat the procedure or try the manual lighting options on next page.**

**5. Upon successful lighting, repeat the process on the other burners you wish to light.**

**6. To shut off the burners, rotate the knob and turn to OFF.**

**7. It is normal to hear a popping sound when the burners are turned off.**



## **LIGHTING THE GRILL**



**CAUTION:** Do Not use any of these alternative lighting options in conjunction with the Gas Burners, Serious Injury or Fire may result.

### **Optional Charcoal Starters are not included**

#### **1. Lighter Fluid**

The most common way to light charcoal briquettes is with charcoal lighter fluid—an easily ignitable, petroleum-based product.



#### **2. Electric Charcoal Lighter**

Electric charcoal lighters look like an elongated outline of a Ping-Pong paddle. That outline is the lighter element loop that, when plugged in, glows like the heating elements in a toaster.

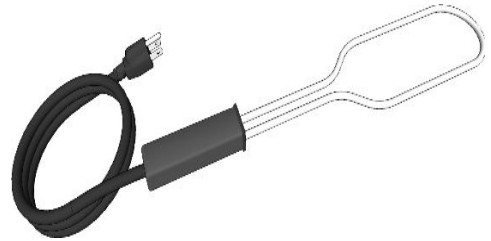

#### **3. Charcoal Chimney Lighter**

A charcoal chimney starter is essentially a metal tube, usually steel, with a handle on the side. Inside is a grate to hold the briquettes and to keep them above the crumpled newspaper, which goes in under the charcoal and is what starts the briquettes. Ventilation holes ring the bottom of the tube.

The goal is to start a charcoal fire without using lighter fluid or other petroleum-based fuels. This is to avoid unpleasant taste to the food, environmental regulations or for other reasons.

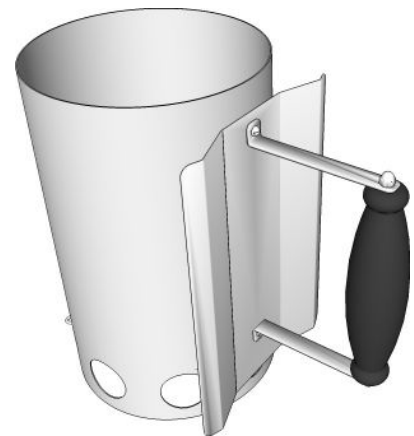

#### **4. Self-Starting Briquettes**

If you don't want to fool around with lighter fluid, there is one more alternative—self-lighting charcoal briquettes. With these, all you do is pile the briquettes on the grill, light them with a match or butane lighter, and you have an almost instant fire. Some grillers like to use these as starters, with a mixture of regular briquettes. One thing to note, however: self-lighting briquettes are not recommended for use with chimney starters.

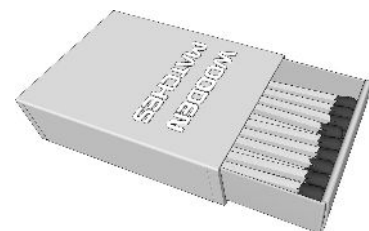

## **USING YOUR GRILL**

### **Dual Zone Cooking**

Your Emerald Grill is divided into two individual cooking zones, each cooking zone is designed to be controlled individually by how the top adjustable rack is positioned, and the front air intake slider is adjusted. Depending on how you independently configure these components, will give you control over diverse types of cooking, including Smoking, Indirect, Slow Cooking and Direct Cooking.

### **Grilling Combination**

Your Emerald Grill is designed for an exquisite cooking experience with the use of three separate grilling surfaces in one. This enables you to be simultaneously searing your food on one side, while slow cooking or smoking on other side and slow simmer on top warming rack. The two individual drawer systems allow you to individual control how much either Charcoal or Wood materials you want to grill with also use multiple types, for some amazing flavors.

### **Heat Distribution**

Knowing how to configure the different components will give you the very best possible food positioning while grilling. Depending on how you position you're Charcoal or Wood. The Cooking Rods have Variable Spacing for different sized foods, and the Sear Zone Grilling Grate will Sear your Steaks at over 800 Degrees depending on how hot your Charcoal or Wood is below. It is important to play with many variations to find what way of grilling is best for you.

### **Indirect Cooking**

Indirect cooking is the process of cooking your food without the heat source directly under your food. You can sear meats over a high flame on one side of the grill while slow cooking on the other side of the grill. It is like cooking in an oven and is generally used for larger cuts of meats but can also be used for cooking foods that are prone to flare ups. Indirect Cooking will result in tender foods every time you grill.

### **Direct Cooking**

Direct cooking is the process of cooking your food directly over hot coals. This method is also called Searing, Grilling or even Frying. Direct cooking is recommended for most grilling applications, and the best place to perform Direct Cooking is in the place where the cooking surface is the hottest. This type of cooking locks in flavor and juices while allowing the outer surface to absorb smoke and food aroma that is produced as grease and drippings are vaporized by the coals. The result is a crisp, flavorful outside with a tender, juicy inside.

### **Smoker/Steamer Box**

Adding the smoker box to your cooking experience adds unique flavor to your food, you will come to enjoy. Use it for either a smoker box with wood chips, or by filling with Water it becomes a steamer box. While in use, remember to close the hood. There are many different wood chips available on the market, the most common are mesquite and hickory. Just remember to soak the chips for 30 minutes prior, for best results.

# GRILL PARTS DIAGRAM

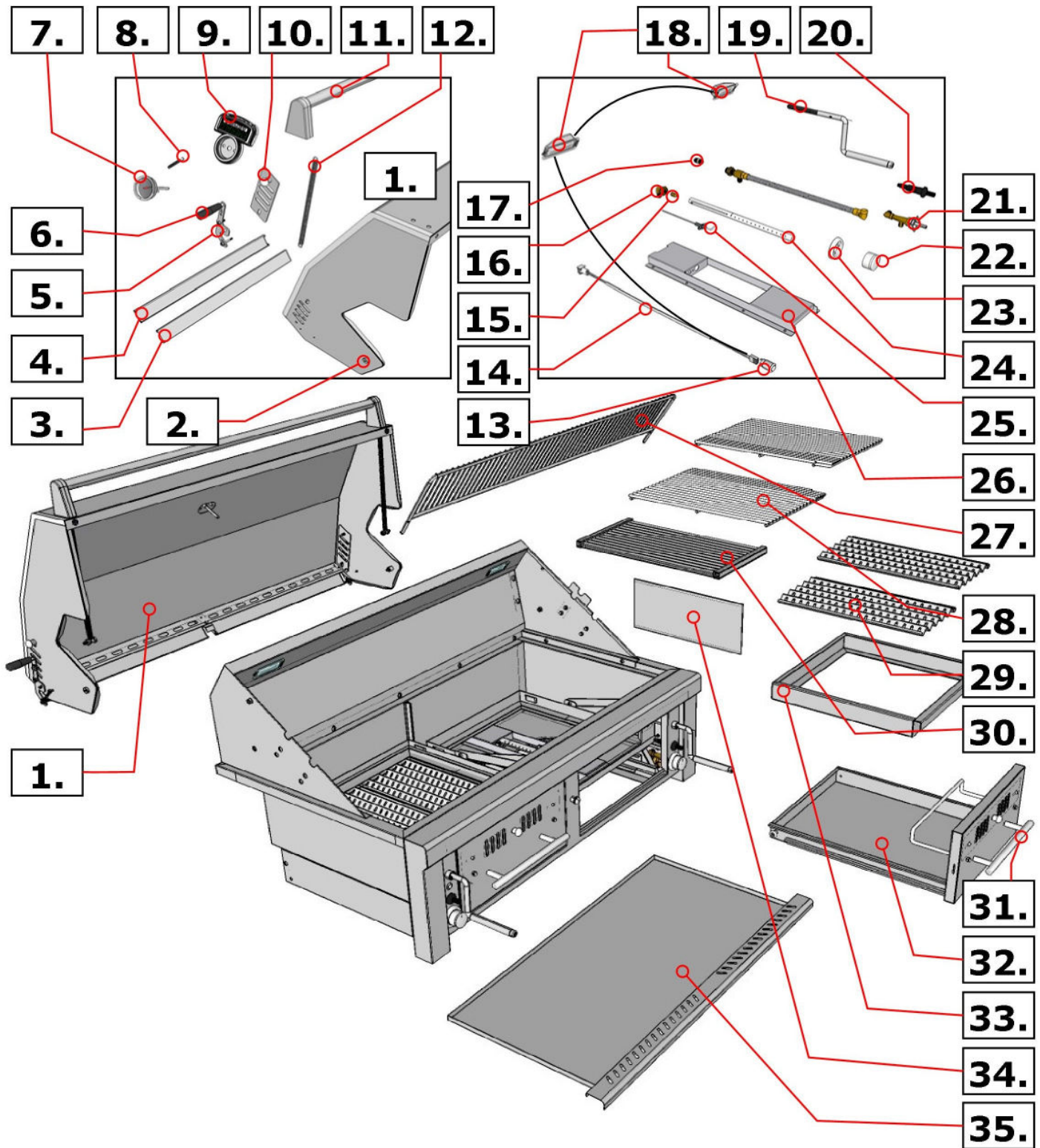

**⚠ ATTENTION:** If you do not see the specific part you are needing replaced, please visit our website at [www.sunstonemetalproducts.com](http://www.sunstonemetalproducts.com). For further assistance please call our Technical Support Office at 888-934-9449.



## Grill Gas Conversion

### **IMPORTANT!**

The Best time to perform this conversion is before grill has been installed into island enclosure. As you will need access Multiple parts of the Back Underside of Grill where Gas Line hooks up and Two positions of Flare Adapters. Accessing this location afterwards requires either removing the grill from island or crawling underneath grill through an access door to reach back underside of grill.

## Island Safety Vent Installation for either Liquid Propane or Natural Gas

### **For Natural Gas**

Natural Gas (NG) is Lighter and will raise to upper end of structure upon leak. Outdoor Kitchen Islands housing Natural Gas Appliance must have several vents located at the approximate level as the Appliance Control Panel, were Knobs are located.

### **For Propane Gas**

Liquid Propane Gas (LP) is Heavier and will lower to base of structure upon leak. Outdoor Kitchen Islands housing Propane Gas Appliance must have several vents located within 4" to 6" from ground level.

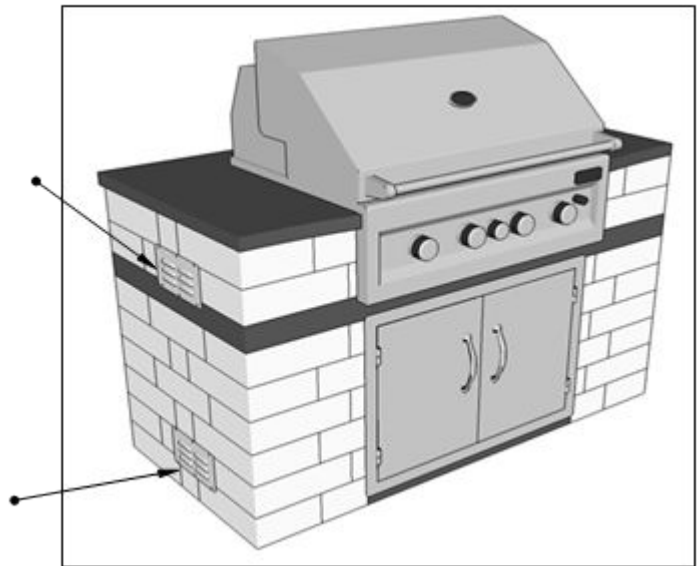

## Grill LP to NG Gas Conversion

This Gas Conversion requires the following parts (Included in Kit)

(1) #50 Drill Bit



(1) NG Regulator  
with 3/8" Flare Adapter

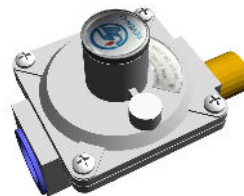

The following tools are recommended (Not Included in Kit)

Wrench



Power Drill



## Grill Gas Conversion

### **1. Reveal Grill Firebox**

Remove from the Grill ALL Burn Trays, Cooking Grates, Sear Grate, and clean out any residue. Turn each Burn Tray Cranks so that the Burn Tray Racks are placed to the lowest position. You can tilt the waring rack into the Stow-Away position instead of removing it. Now look towards the back of each burner position Left and Right, you will notice a Flare Adapter coming in though the back wall panel.



**The Following Steps illustrate the LP to NG Flare adapter change to the RIGHT Side Flare Adapter ONLY. You will also be required to follow the same steps when modifying the LEFT Side Flare Adapter to NG gas type.**

## Grill Gas Conversion

### **2. Unscrew Brass Flare O-Ring**

Using the recommended “Needle Nose Pliers” – unscrew the brass O-Ring which is securing the Flare Adapter tightly in place, with it’s nose end inserted into the open burner hole port.



### **3. Stow-Away the O-Ring**

Important! Be sure to slide the brass O-Ring, if O-Ring falls below it may be very difficult to pull it back up as it is a very small area with limited access under burner compartment.



### **4. Push the Flare Adapter Out**

Push the Flare Adapter out through the port-hole, while keeping the Brass O-Ring stationary on the end of Burner.

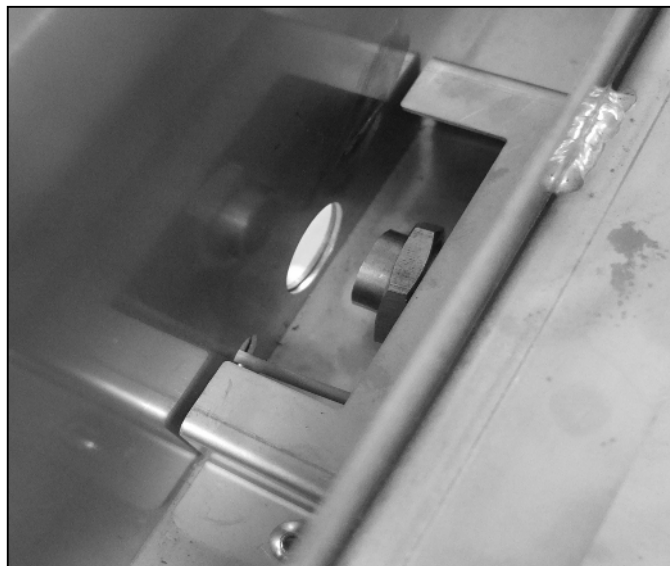

### **5. Locate the Flare Adapter in Back**

If the Flare Adapter has not been pushed out all the way, do that now by pulling it out, and rotate it slightly revealing the Orifice Hole at tip the Tip of the Flare Adapter Cone.

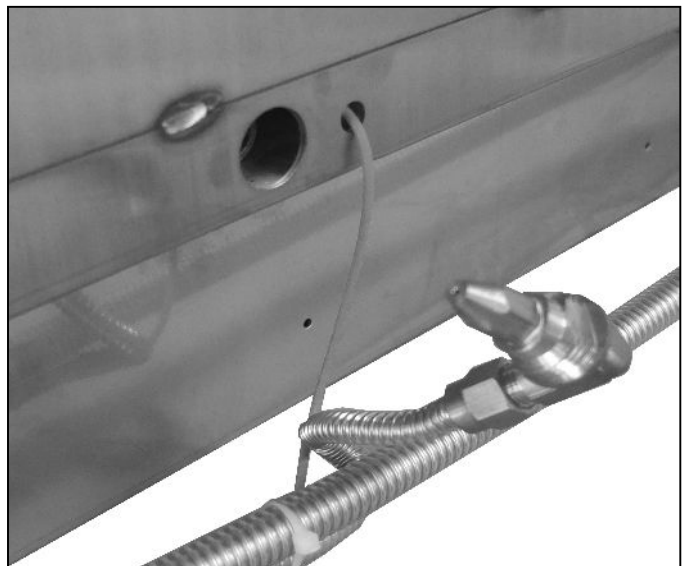

## Grill Gas Conversion

### **6. Prep #50 Drill Bit & Power Drill**

Secure the #50 size Drill-Bit and install it into the Power Drill. While grasping the Elbow of the Flare Adapter – Align to the tip of drill bit so your drill-bit is perfectly aligned to orifice hole.



### **7. Drill the Adapter Orifice**

Aligning Drill to Flare Adapter, Push the Spinning Drill into the center of Orifice Hole approx. 1/8<sup>th</sup> Inch then pulling out, lastly blow some air into tip clearing any small particles.

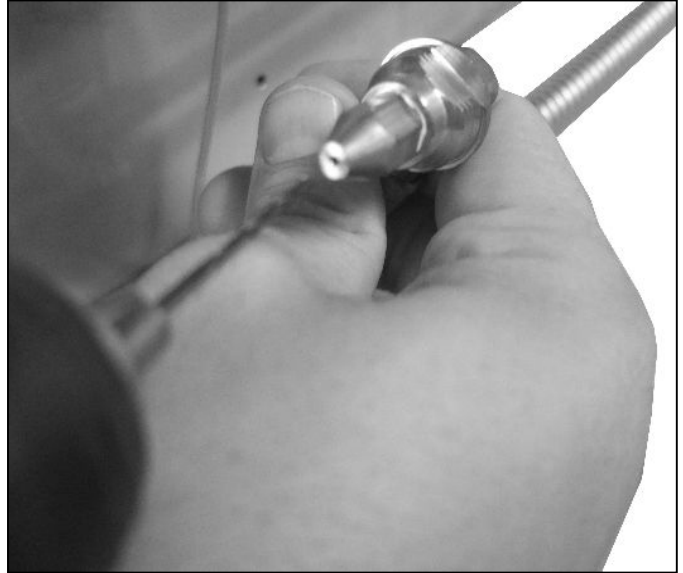

### **8. Fasten the New NG Regulator**

Fasten on the NG Regulator, with the Female Flare Adapter connecting to the Grills Right Back Side Gas Manifold Male Flare Adapter. Notice Arrow indicating direction of Gas Flow.

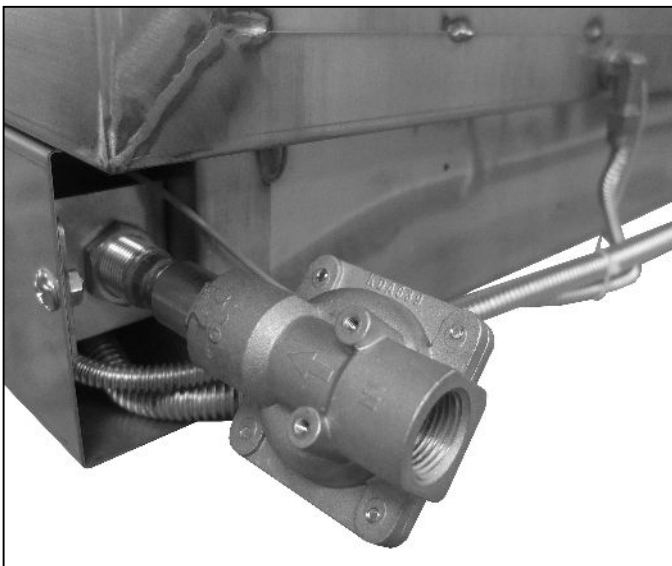

### **9. Finalize LP to NG Conversion**

The NG Regulator will have a 1/2" Female Flare Adapter on other end, try our 18" Black Hose, or a Quick Disconnect – Always have a Licensed Plumber make this final connection.

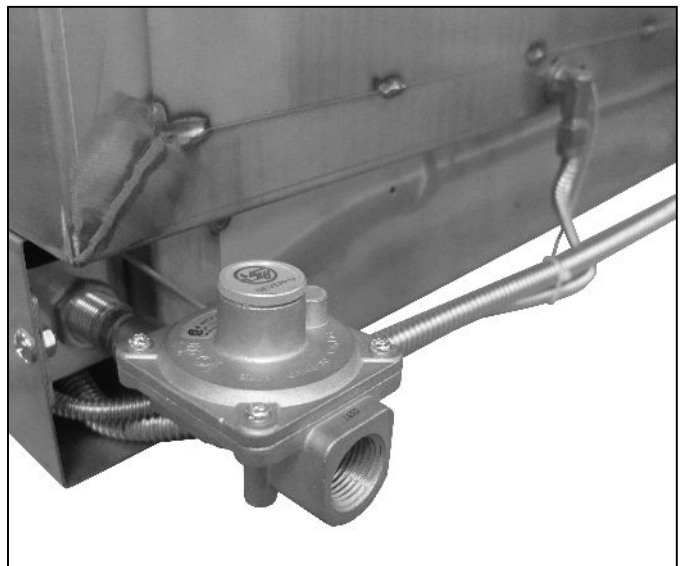



## **Grill Trouble Shooting**

### **Q. Grill Gas Burner Doesn't Ignite, when pressing in the Black Ignition Button**

**A.** Remove the Cooking Grates, Burn Trays and Locate the Back of each Gas Burner where you will see a small Angled Metal Prong, this is the Impulse Igniter. When you press in the Black Igniter Button, an Electrical Impulse travel down the connecting wire to this Metal Prong, resonating at the Point and will then Ark over to the adjacent Burner. If the Burner is Not Clean enough, it will diminish the amount of surface area the ARK can impact and thus it will not ARK and the gas will not ignite.

### **Q. LED Light is not functioning while interior lights are ON**

**A.** Likely your LED Light has malfunctioned do to the grill being Overheated, or there may be a loose wire on the internal control circuit board. You can access these components by sliding the grill out from your island approx. 6 Inches, there are 4 screws on either side holding the front control panel to grill body, and 4 Alan Wrench Screws on the inside facing towards front panel, you will see 4 Holes. Removing these screws will allow the main control panel to be removed revealing the internal LED light and Circuit Board. You can then easily unplug and replace LED light with new one or check for other loose connections.

### **Q. Either One or Both Interior Lights do not work but LED Light works**

**A.** Most often the interior Halogen Lights will burn out One at a time, if both are out at the same time, you could have a connection issue. Check the Plug in the back bottom Left of grill, the plug consists of two sockets on either side, check to make sure each is securely pushed in. If all the Lights do not work, then it is either unplugged or the Transformer has malfunctioned. Each Halogen light can be replaced by unscrewing a single screw per light located on left sides of light cover, the entire light box needs to be removed, there are two small black wires hard-plugged into back of light. Use a pair of plyers to remove these, replacing to new Halogen Light box, again use a pair of plyers to push each wire into each socket of light box, Test light is working before inserting back into hole and again tightening the small screw on left outer side.

### **Q. The Gas Burners flame is very Low**

**A.** If your grill is using a 25 Pound Portable tank and is directly connected to grill with no other appliance, you may have a Spider Web or other clog in the gas Pipe. If your grill is connected to a Side Yard 500 Gallon Tank, there may be an issue with the Regulator – either it is a Low-Pressure Regulator being used, or not enough gas pressure is being allowed to the grill. If you have any T-Connections in gas line going to other outdoor Appliances like a Fireplace or Side Burner, this can also greatly diminish gas flow.

# **GRILL WARRANTY**

## **SUNSTONE SERIES 42" GAS HYBRID CHARCOAL GRILL WARRANTY**

**\*\*\*All Warranties Start from the Date of Purchase\*\*\***

### **LIMITED LIFETIME WARRANTY**

*Sunstone Stainless Rod Cooking Grids and Stainless-Steel Housings (including liners, frames, firebox and hood and all exterior grill faces) are warranted for as long as you own you're Sunstone Barbecue Grill against all factory defects. This warranty does not cover against consumer usage wear and tear from using the grill as all grilling methods will erode the 304 Stainless Steel Materials.*

### **LIMITED LIFETIME WARRANTY WITH ONE YEAR BURNER REPLACEMENT**

*The Stainless-Steel Gas Tube Burner is warranted for as long as you own you're Sunstone Barbecue Grill against all factory defects. In addition, the Burner is covered for the first full year from date of purchase with FREE replacement against all wear and tear. This warranty covers the burner only, it does not cover the cost of a service tech to replace the burner.*

### **LIMITED ONE-YEAR WARRANTY**

*All other grill components including, thermometer, light assemblies, gas-valves, piezo-igniters, springs, all electrical wire are warranted to be free from defects in material and workmanship for a period of one year from the original date of purchase.*

### **LIMITATIONS & EXCLUSIONS**

1. *SUNSTONE warranty applies only to the original purchaser and may not be transferred.*
2. *SUNSTONE warranty is in lieu of all other warranties expressed or implied and all other obligations or liabilities related to the sale or use of its grill products.*
3. *SUNSTONE warranty shall not apply, and SUNSTONE is not responsible for damage resulting from misuse, abuse, alteration of or tampering with the appliance, accident, hostile environment, flare-up fires, improper installation, or installation not in accordance with the instructions contained in the User Manual, or the local codes.*
4. *SUNSTONE is not responsible for warping of component parts due to overheating or using in a way not in line with the product manual.*
5. *SUNSTONE shall not be liable for incidental, consequential, special or contingent damages resulting from its breach of this written warranty or any implied warranty.*
6. *Some states do not allow limitations on how long an implied warranty lasts, or the exclusions of or limitations on Consequential damages. This warranty gives you specific legal rights and you may have other rights, which vary from state to state.*
7. *No one has the authority to add to or vary SUNSTONE warranty, or to create for SUNSTONE any other obligation or liability in connection with the sale or use of its products.*
8. *SUNSTONE DOES NOT COVER FOR WARPING OF STEEL DRAWER, GRATES, OR ANY OTHER COMPONENT FROM THE RESULT OF MISUSE OR OVERHEATING OF COMPONENTS.*

### **WHAT IS NOT COVERED. & INTERNET PURCHASE DISCLAIMER**

1. *SUNSTONE shall not be responsible for and shall not pay for the following Installation or start-up.*
2. *Service by an unauthorized service provider and the cost of a service tech of any warranted parts.*
3. *Damage or repair due to service by an unauthorized service provider or use of unauthorized parts.*
4. *Damage caused by accidents, abuse, alteration, misuse, installation that is not in accordance with the instructions contained in the User Manual, or local codes.*
5. *To correct normal adjustments or settings, due to improper installation, commissioning or local gas supply properties.*
6. *Shipping and handling costs, export duties, or installation cost.*
7. *The cost of service calls to diagnose trouble; or Removal or re-installation cost.*

This warranty applies to the original purchaser with invoice or proof of purchase and covers Sunstone products intended for personal, family or household usage only. It does not apply to surface rust, corrosion, oxidation or discoloration, which may occur due to moisture or overheating, unless the affected component becomes inoperable. This warranty does not cover parts becoming defective by misuse, accidental damage, improper handling and/or installation. It does not cover labor or labor related charges. It specifically excludes liability for indirect, incidental or consequential damages. Some states do not allow the exclusion or limitation of incidental or consequential damages, so the above exclusion or limitation may not apply to you. This warranty gives you specified legal rights and you may have other rights which may vary from state to state. For additional information regarding this warranty, or information on how to place a warranty claim, contact your authorized Sunstone dealer.