



**Read all instructions before you operate your grill.
Save these instructions!**



Intertek

3174816

Certified to:

UL SUBJECT 2728A

ULC/ORD-C2728

MODEL NO: SUNPLT40

Fuel input rating: 1.7LBS/hr

Electrical Rate: 120Vac, 60Hz, 485W – 4.4 AMPS

Refer to Intertek's Directory of Building Products for detailed information.

Minimum clearance from side and back of unit to combustible construction: 24" (609.6mm) from sides and 24" (609.6mm) from back.

Welcome & Congratulations

Congratulations on your purchase of a new Sunstone Pellet Grill! We are very proud of our product, and we are completely committed to providing you with the best service possible.



ATTENTION: Please read this entire manual before installation and use of the pelletized, all natural, wood fuel-burning appliance. Failure to follow these instructions could result in property damage, bodily injury or even death. Contact local building or fire officials about restrictions and installation inspection requirements in your area.

Save these instructions.

How to Obtain Service

Before you call

Please make sure you have the following information:

MODEL NUMBER | DATE OF PURCHASE | INVOICE NUMBER.

To installer or person assembling grill: Leave this manual with grill for future reference.

To consumer: Keep this manual for future reference.

For warranty service, contact SUNSTONE Customer Service Department at (888)-934-9449 or email: service@sunstonemetalproducts.com.

SUNSTONE METAL PRODUCTS LLC.
16004 Central Commerce Dr, Pflugerville Texas 78660.

Business Hours.

Mon. to Thur. 9:00AM to 4:30PM

Closed Fri/Sat/Sun

Tel: 512-487-5116

Toll Free: 888-934-9449 (Technical Support Line)

Fax: 512-487-7016



ATTENTION: If Fire Occurs: Call Fire Department. Do Not: Try to Move Appliance, Try To Smother Fire, Or Put Water On The Fire. Keep The Appliance Clean – See Instruction Manual for Cleaning And Proper Operation. Always Operate Appliance With Doors Of Room Open (For Appliances That Are Intended For Indoor Use)



BODILY INJURY: Improper Use Can Cause Uncontrolled Fire. To Reduce Fire Risk This Appliance Is Intended to Burn (pelletized, all natural, wood) Fuel Only. Where (pelletized, all natural, wood) Is the Fuel. Manufacturer's Name or Fuel Trade Name and Distinctive Model Designation. Operate Only Per Manufacturer's Instructions. Never Use Gasoline or Lighter Fluid. Always Store Wood Pellets Away from Heat-Producing Appliances and Other Fuel Containers.

INDEX DIRECTORY

PREPARATION

REQUIREMENTS	1
CHECKLIST	2
PELLET STORAGE	3

GRILL PARTS

PARTS LIST	4
DIAGRAM	5

MEASUREMENTS

TECHNICAL	6
CUT-OUT	7

INSTALLATION

BUILT-IN DIAGRAM	8
DOORS/DRAWERS	9
SUNSTONE CABINTRY	10
SAFETY GUIDELINES	11
ISLAND CONSTRUCTION	12
STEP BY STEP GUIDE	13

GRILL START-UP

GRILL SEASONING	14
BUILDING THE FIRE	15
USING THE GRILL	16
INITIAL STARTUP	17
GRILLING MODES	18
GRILL OPERATION	19
FUEL SAFETY	20

TROUBLE SHOOTING

QUESTION & ANSWER	21
ERROR CODES	22
ELECTRICAL	23

GRILL WARRANTY

24

HAZARDS & WARNING SIGNS



ATTENTION: Indicates a potentially hazardous situation which, if not avoided, may result in minor or moderate personal injury, or property damage.



WARNING: Indicates an imminently hazardous situation which, if not avoided, will result in death or serious injury.



VOLTAGE: Indicates a potentially hazardous situation which, if not avoided, may result in minor or moderate electrical shock.



EXPLOSION: Indicates an imminently hazardous situation which, if not avoided, will result in possible explosion and cause death or severe injury.



BODILY INJURY: Indicates a potentially hazardous situation which, if not avoided, may result in minor or moderate personal injury, or property damage.



HOT SURFACE: Indicates an imminently hazardous hot surface which, if not avoided, will result in serious burn or injury.



LIVE CIRCUIT: Indicates a potentially hazard from Live electrical current that if extreme caution is not used, may result in minor or moderate personal injury, or property damage.

Copyright 2023. All rights reserved. No part of this manual may be copied, transmitted, transcribed, stored in a retrieval system, in any form or by any means without expressed written permission.



ATTENTION: A MAJOR CAUSE OF FIRES IS FAILURE TO MAINTAIN REQUIRED CLEARANCES (AIR SPACES) TO COMBUSTIBLE MATERIALS. IT IS OF UTMOST IMPORTANCE THAT THIS PRODUCT BE INSTALLED ONLY IN ACCORDANCE WITH THESE INSTRUCTIONS.



ATTENTION: Do not use spirit, petrol, gasoline, lighter-fluid or kerosene for lighting or refreshing a fire in your grill. Keep all such liquids well away from the appliance when in use.

Countertop support: The countertop should be able to support the weight of the pellet grill and any other items that will be placed on it. It's important to ensure that the countertop is strong and stable enough to support the weight of the grill, as well as any movement or vibration caused by the operation of the grill.

Adequate clearance: The area beneath the pellet grill should be clear and free of any obstructions or combustible materials that could be damaged by heat or sparks. Ensure that there is adequate clearance of at least 6" behind the grill for air flow and to allow the hood to open without any obstruction.

Ventilation: The grill should be in an area that allows for proper ventilation, with sufficient space around the grill to prevent any heat buildup or damage to the countertop. It's important to maintain a clearance of 24" Minimum between the grill and any nearby Combustible Materials, and Never build your island using combustible materials to prevent any safety hazards, risk of fire or injury.

Power source: The Pellet Grill is 120Vac, 60HZ, 485W – 4.4 AMPS and requires an electrical outlet that can deliver 120 volts of alternating current (Vac) at 60 hertz (Hz), with a minimum of 4.4 amps of current. Ensure that the electrical outlet is properly grounded and in good condition to prevent any safety hazards.

Safety precautions: Follow all safety precautions and guidelines provided in this Manual during the installation and operation of the pellet grill. Never leave the grill unattended, always use the grill in a safe and responsible manner, and follow all local codes and regulations related to the installation and operation of outdoor cooking equipment.

Check List for pellet grill Startup and Usage:

- ✓ Transformer Electrical Plug is properly installed.
- ✓ Keep electrical supply cords away from heated surfaces.
- ✓ Do not use your grill in the rain or around any water source.
- ✓ After a period of storage or non-use, check the burn grate for obstructions and the hopper for air blockage. Clean before use.
- ✓ If the grill is stored outside during the rainy season or seasons of high humidity, care should be taken to ensure that water does not get into the hopper.
- ✓ Always disconnect the power before performing any service or maintenance.
- ✓ This pellet cooking appliance is designed and approved for pelletized, all natural, wood fuel only. Any other type of fuel burned in this appliance will void the warranty and safety listing.
- ✓ Only use all-natural wood pellets designed for burning in pellet barbecue grills. Do not use fuel with additives.
- ✓ Maintain a minimum 24-inch clearance to combustible materials.
- ✓ Ensure that all packaging has been removed from the interior of the grill.
- ✓ Make sure that all parts and components are properly installed.

By following this checklist, you can ensure that your pellet grill is properly installed, safe to use, and ready to deliver delicious outdoor cooking experiences. It's important to always prioritize safety and to follow the manufacturer's instructions carefully when setting up and using your pellet grill.

When it comes to pellet storage, there are several methods and recommendations that can help ensure the quality and longevity of your pellets.

1. **Store in a dry place:** It's important to keep your pellets dry, as moisture can cause them to deteriorate and even mold. Store your pellets in a dry place, such as a garage or shed, where they are protected from the elements.
2. **Keep away from heat:** Pellets can also be damaged by heat, so it's important to store them in a cool area away from direct sunlight or other sources of heat.
3. **Use airtight containers:** To keep your pellets fresh and prevent them from absorbing moisture, consider storing them in airtight containers or bags. This will help to maintain their quality and ensure they are ready to use when you need them.
4. **Keep away from pests:** Pellets can attract pests such as rodents and insects, so it's important to store them in a location that is inaccessible to these pests. Consider storing them on shelves or in containers with tight-fitting lids to prevent any unwanted visitors.
5. **Rotate your stock:** To ensure that your pellets are always fresh and ready to use, it's a good idea to rotate your stock periodically. This means using the oldest pellets first and replenishing your supply with fresh pellets.

By following these methods and recommendations, you can ensure that your pellets are stored properly and are always ready to use when you need them. This will help to maximize the life and quality of your pellets and ensure that you can continue to enjoy your pellet grill for years to come.

NUMBER	DESCRIPTION	#	PART NUMBER
1	Temperature Gauge	1PC	RUBY-TMETER
2	Left Handle Assembly	3PC	PLT40-LHANDLE
3	Right Handle Assembly	3PC	PLT40-RHANDLE
4	Hybrid Grill Badge	1PC	PLT40-HGBADGE
5	Left Loader Hood	1PC	PLT40-LLHOOD
6	Right Grill Hood	1PC	PLT40-RGHOOD
7	Hood Bolt Screw Set	4PC	PLT40-HBSCREW
8	Halogen Light	3PC	PLT40-HLIGHT
9	Grill Smoker Hooks	5PC	PLT40-GSHOOKS
10	Pellet Loader Baffle Plate	1PC	PLT40-PLBAFFLE
11	Cold Smoker Container Tube	1PC	PLT40-CSCTUBE
12	Cork-Screw Pipe Auger	1PC	PLT40-CSAUGER
13	Auger Base Trough	1PC	PLT40-ABTROUGH
14	Small Motor Assembly	1PC	PLT40-SMOTOR
15	Pellet Line Feeder	1PC	PLT40-PLFEEDER
16	Cold Smoker Shute Box	1PC	PLT40-CSSHUTE
17	Cold Smoker Ignition Stick	1PC	PLT40-CSIGNITION
18	Combustion Chamber	1PC	PLT40-CCHAMBER
19	Power Line Plug	1PC	PLT40-PLINE
20	Thermometric Assembly	1PC	PLT40-THERMO
21	Warming Rack - Small	1PC	PLT40-WSRACK
22	Warming Rack - Medium	1PC	PLT40-WMRACK
23	Straight Cooking Grate	1PC	PLT40-SCGRATE
24	Cooking Grate w/Insert	1PC	PLT40-ODAGRATE
25	Oil Deflector Assembly	1PC	PLT40-ODEFLECTOR
26	Oil Deflector Inset Panel	1PC	PLT40-ODEFPANEL
27	Main Combustion Chamber	1PC	PLT40-MCCHAMBER
28	Oil Baffle Support Panel	1PC	PLT40-OBAFSPANEL
29	Main Ignition Stick	1PC	PLT40-MIGNITION
30	Electric Rotating Fan	2PC	PLT40-ERFAN
31	Rotating Fan Cover	1PC	PLT40-RFCOVER
32	Control Panel	1PC	PLT40-CPANEL
33	Main Control Panel	1PC	PLT40-MCPANEL
34	Front Panel Speed Rail	1PC	PLT40-FPSRAIL
35	Front Base Venting Panel	1PC	PLT40-FBVENTING
36	Oil Tray Assembly	2PC	PLT40-OTRAY

Refer to page 4 Parts List

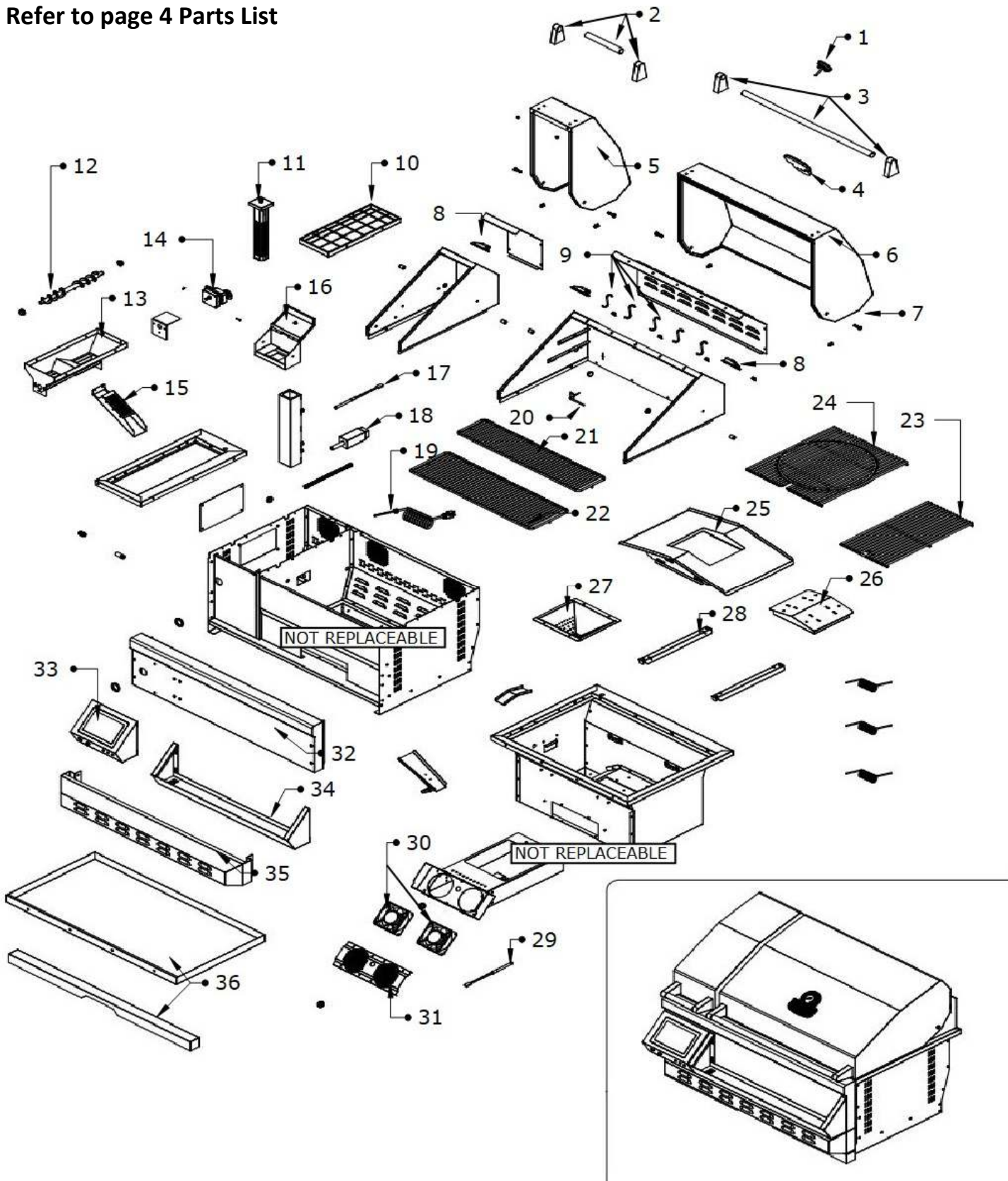

MEASUREMENTS – TECHNICAL

Product Size

Overall Width-----	40"
Overall Height-----	30.94"
Overall Depth-----	30.14"

Firebox Size

Box Width -----	38.43"
Box Height-----	16.84"
Box Depth-----	21.85"

FRONT VIEW

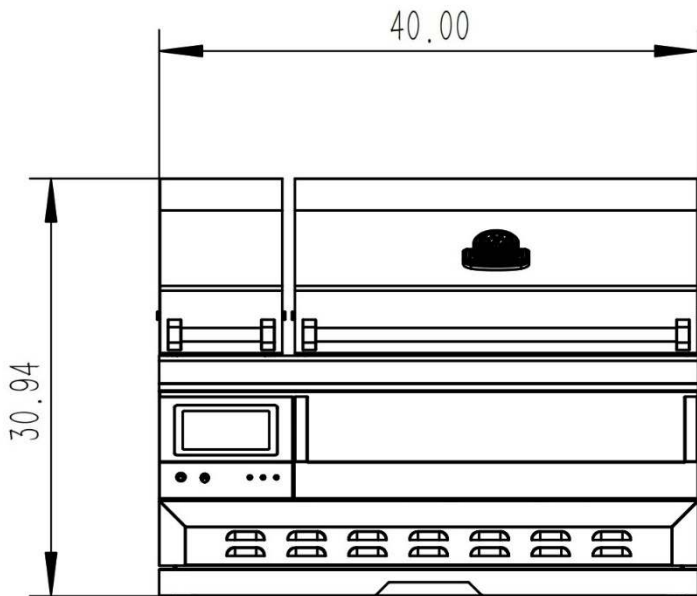

SIDE VIEW

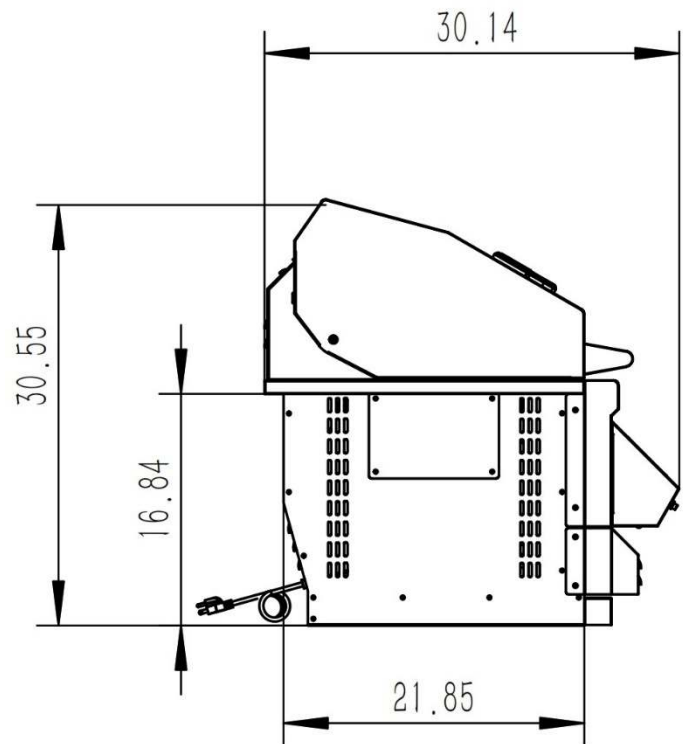

BACK VIEW

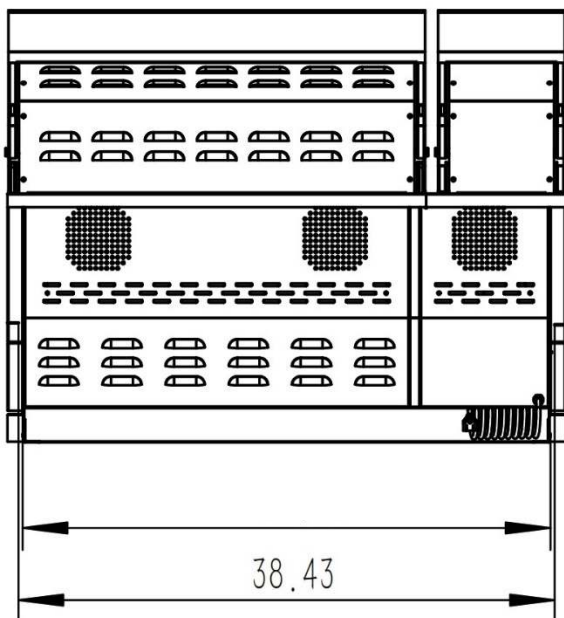

TOP VIEW

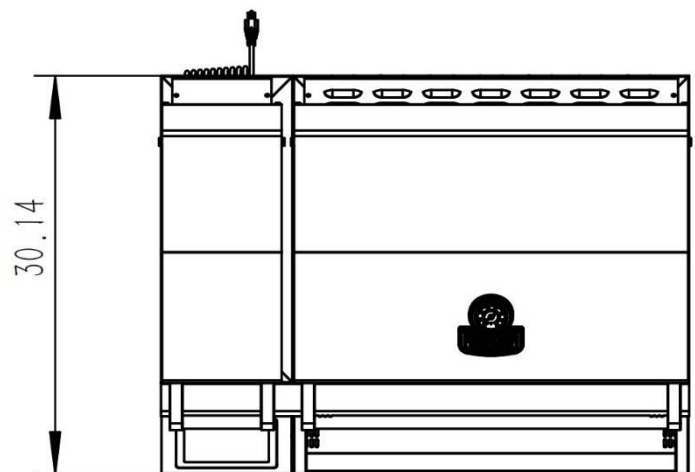



ATTENTION: Never build an enclosure under the Grill or partition side walls, the Grill must be Free Hanging supported by the countertop only! Must have clear access to underside of Grill within reach of at least Two Vents.

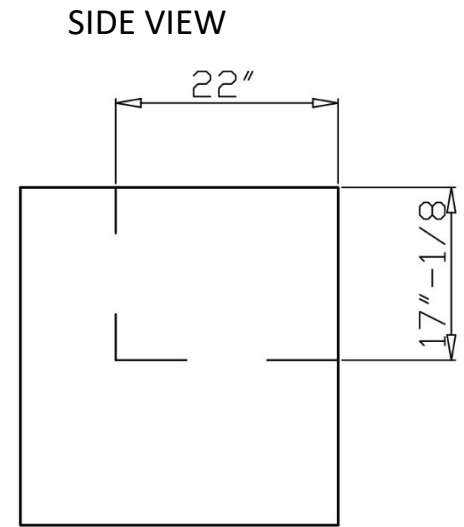
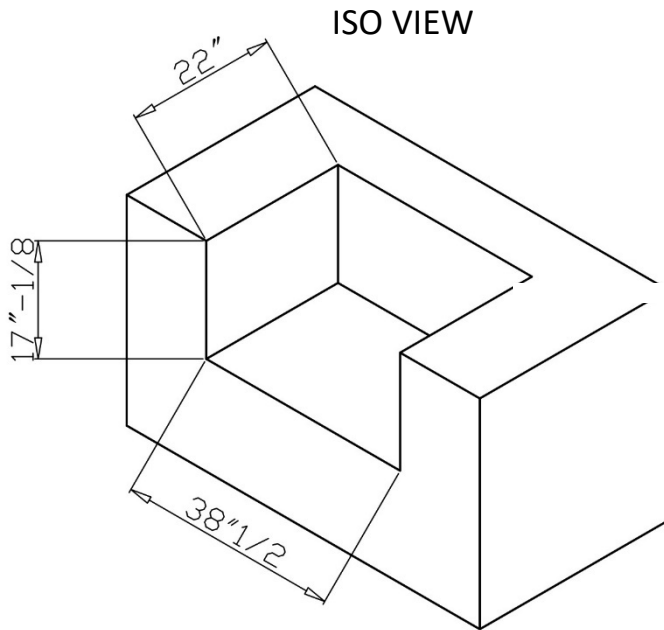

TOP VIEW



FRONT VIEW

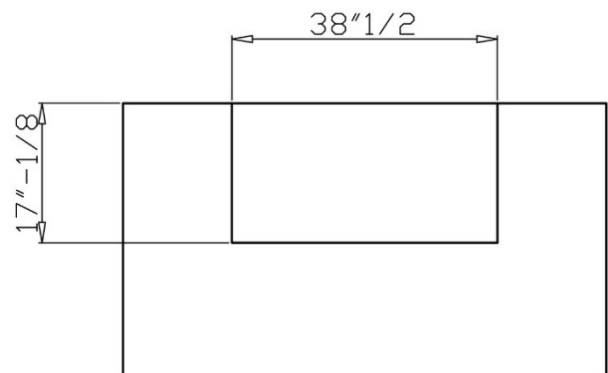

Countertop Slide-in Installation

- Grill Cut-out Depth ----- 22 Inch Depth
- Grill Cut-out Height (Allow 3/4" Air-Flow Gap Below Drip Pan) ----- 17-1/8 Inch Height
- Grill Cut-out Width----- 38-1/2 Inch Width
- ✓ Make 1-3/4" W x1"D Notch Cut-Out on both sides of cut-out counter edge, to allow grill to slide flush against the island finish wall.
- ✓ Leave Minimum 3/4" Gap below Drip Pan for Air/Gas Ventilation
- ✓ Must have TWO Vents in HIGH position for Air Circulation

Enclosed Installation Definition:

Structure built above Appliance that is attached to the home’s exterior outside wall, roof or is inside a separate structure like outdoor room and there is a Minimum of “One” Side open with outside exposure.

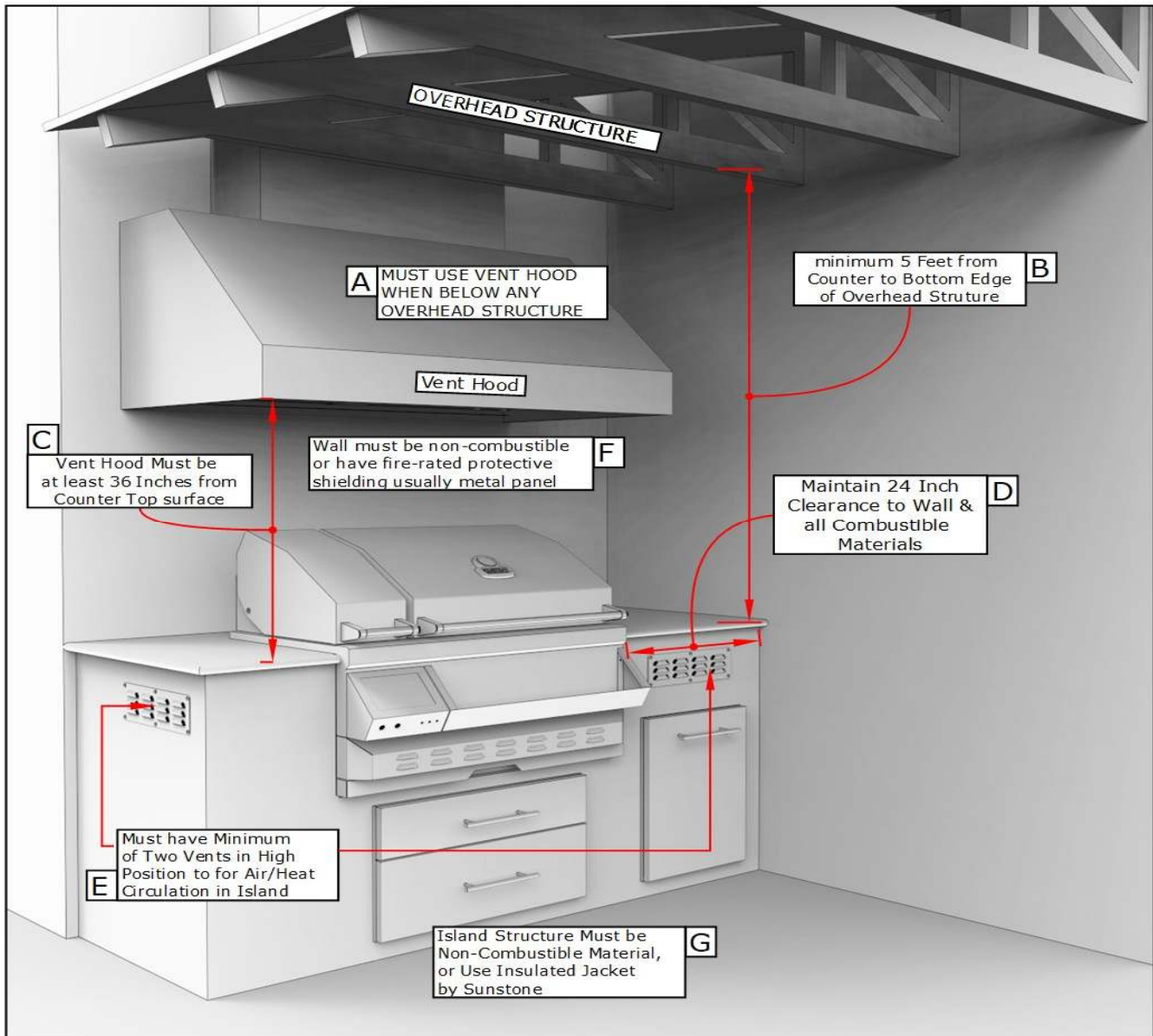

Minimum Distances to Combustible Materials or other Appliances ONLY, Non-Combustible materials do not apply!

- (A) Must use vent hood above grill for enclosed structures
- (B) Minimum 5 Feet distance from counter to overhead structure 5’ Min.
- (C) Vent Hood Must be at least 36 Inches from Countertop
- (D) Minimum 24 Inch clearance from all combustible materials
- (E) Must have TWO Vents in HIGH position for Ventilation
- (F) Install Non-Combustible Barrier Shielding, Stainless Steel Sheet is recommended.
- (G) Island Structure must be Non-Combustible otherwise must use grill jacket or metal cabinet.

Access Doors & Drawers

Due to the height of a pellet grill, which sits at over 17 inches below the counter level, placing access doors beneath the grill can be difficult. While some 14x20 horizontal doors may function well, in most cases, it is recommended to use a few of our 30" Designer Series Drawers, Item No. DE-MD30 or DE-SD30. These drawers provide ample storage space while also being easily accessible.

It is important to note that since this is an Electrical Pellet Grill, there is no need to place access doors beneath it. This is because there are no gas lines or propane tanks that require access. However, if you have a gas grill or side burner incorporated into your outdoor kitchen island, then it is recommended to use any of our access doors.

Proper use of access doors is an essential part of designing a functional outdoor kitchen island. When planning your outdoor kitchen, consider the placement of your pellet grill and other appliances, and whether access doors are necessary.

In addition to considering the placement of access doors, it is important to choose high-quality doors that will withstand the rigors of outdoor use. Our access doors are constructed from high-quality 304 Stainless Steel Materials, ensuring durability and long-lasting performance.

Recommended Sunstone Doors & Drawers for use with the Built-in Pellet Grill:

All recommended components fit within 14" clearance which still allows for structural framing of outdoor kitchen island.

Classic Series	Signature Series	Designer Series
C-SD12	BA-SD12	DE-SD30
C-VSDL/R12	BA-VSDL/R12	DE-MD30
DH140	BA-DH1420	DE-DPCF13
A-DH1420	BA-VDHR1420	DE-DD13
B-SD6	BA-SD6	
B-DD12	BA-DD12	

The Sunstone Pellet Grill is the perfect addition to our outdoor kitchen cabinets.

The Pellet Grill is designed to fit seamlessly into our Grill Cabinet Item No. SAC44GPTD, allowing for easy installation and customization. The cabinet is made with the same high-quality 304 stainless steel and is built to withstand the harsh outdoor elements. It comes with two large drawers that can hold pellets for the main hopper and the built-in cold smoker, making it convenient to store and use.



Item No. SAC44GPTD

Safety First - No Combustible Materials and Built-in Venting with the Bottom Vent

At Sunstone, we take safety seriously. That's why the Sunstone Grill Cabinet is designed with safety in mind. It features a built-in venting system with a bottom vent that allows for proper airflow, preventing the build-up of harmful gases. Additionally, the cabinet is designed with no combustible materials, eliminating the risk of fires or explosions.

Easy to Use - Two Large Drawers for Pellet Storage

The Sunstone Grill Cabinet is easy to use, thanks to its two large drawers for pellet storage. The drawers can hold pellets for the main hopper and the built-in cold smoker, making it easy to switch between the two. This is particularly useful for those who want to smoke meats, fish, or cheese. The built-in cold smoker provides an extra layer of flavor to your dishes, giving you that authentic wood-smoked taste.

Sunstone Stainless Steel Cabinets - The Perfect Choice for Your Outdoor Kitchen

Sunstone Stainless Steel Cabinets are the perfect choice for your outdoor kitchen. They are designed to withstand the toughest outdoor conditions and are built with the latest technology and materials. Whether you are a professional chef or a backyard grill master, our cabinets are the perfect match for your outdoor cooking needs. They are customizable, easy to install, and come with a variety of storage options, making it easy to create the perfect outdoor kitchen for you.

Contact our Sales and Technical Support with any questions: 888-934-9449

DEFINITION OF COMBUSTIBLE MATERIAL - Any materials of a building structure or decorative structure made of wood, compressed paper, plant fibers, vinyl/plastic or other materials that are capable of transferring heat or being ignited and burned. Such material shall be considered combustible even though flame-proofed, fire-retardant treated or surface-painted, or plastered.

Clearances to Combustible Construction:

Minimum of 24" from the sides and rear of grill must be maintained to adjacent vertical combustible construction above the countertop level. You should take in account that there is a large volume of heat, and smoke will exhaust from the rear of the grill. This may discolor or damage unprotected areas, do not install under unprotected combustible construction without using a fire safe ventilation system. A 24" minimum clearance must be maintained under the countertop to combustible construction. The clearance can be modified by a use of an insulated jacket.

Combustible Floor Materials:

When installing a pellet grill, it is important to avoid installation on combustible floors, such as wooden or carpeted floors, to prevent the risk of fire. The Pellet Grill should be installed on non-combustible floors or floors that are protected with non-combustible surfaces. The protective surface should be approved for use by the authority having jurisdiction, which may include local building codes or other regulatory bodies. Examples of noncombustible surfaces that may be suitable for protecting floors during pellet grill installation include concrete, brick, or tile. These surfaces are less likely to ignite if exposed to heat or sparks from the grill and can help to prevent the spread of fire in the event of an accident.

Combustible Ceiling or Overhang:

Installing a pellet grill under a combustible ceiling or overhang increases the risk of fire, as heat and sparks from the grill can ignite nearby materials. Therefore, it is strongly recommended to avoid installing a pellet grill under a combustible ceiling or overhang. If installation in such an area is necessary, a minimum clearance of 5 feet must be maintained between the counter and the overhead ceiling or structure. This will help to minimize the risk of fire and ensure a safe and enjoyable outdoor cooking experience.

Furthermore, all installations under a ceiling or overhang which are above the grill installation must have a vent hood installed at a minimum of 36 inches from the countertop to the bottom edge of the vent hood. This will help to ensure proper ventilation and prevent any heat buildup or smoke damage to the overhead structure.



ATTENTION: Major causes of appliance fires are a result of poor maintenance and a failure to maintain required clearance to combustible materials. Always keep a Minimum of 24 Inch Clearance from ALL Combustible Materials.



ATTENTION: You must contact your local home association, building or fire officials, or authority having jurisdiction, to obtain the necessary permits, mission, or information on any installation restrictions, such as any grill being installed on a combustible surface, inspection requirements or even ability to use, in your area.

Island Safety & Construction

Constructing an outdoor kitchen island is a great way to enhance your outdoor living space and entertain guests while enjoying delicious grilled meals. However, it is important to ensure that your outdoor kitchen island is constructed with proper air-circulation to prevent the build-up of heat and provide safety for your family and property.

When using the Sunstone Pellet Grill, it is essential to have a minimum of two vents set in a high position to allow high heat to escape and provide proper air-circulation. This is especially important when any gas appliances are in use. If you're using Natural Gas, then two vents in a high position are recommended. If you're using Liquid Propane, then two vents - one in a high position and one in a low position - are essential.

This is a safety essential, as more homes burn down every year simply because the homeowner did not properly construct the outdoor kitchen island and have proper air-circulation. Any gas grill or pellet grill holds the heat below the counter surface, unlike an indoor cooktop where the flame is above the counter surface, so a much larger volume of heat can build-up within the island construction.

By providing proper air-circulation and ventilation, you can reduce the risk of fire and ensure that your outdoor kitchen is a safe and enjoyable space to cook and entertain. In addition to proper ventilation, it's also important to follow all safety guidelines for outdoor cooking, including keeping flammable materials away from the grill and keeping a fire extinguisher nearby.

- Proper air-circulation is essential when constructing an outdoor kitchen island with a Sunstone Pellet Grill.
- It is important to have a minimum of two vents set in a high position to allow high heat to escape and provide proper air-circulation.
- For Natural Gas, it is recommended to have two vents set in a high position. For Liquid Propane, it is essential to have two vents in low positions.
- This is a safety essential to prevent the build-up of heat and reduce the risk of fire.
- Any gas grill or pellet grill holds the heat below the counter surface, so a much larger volume of heat can build-up within the island construction.



BODILY INJURY: Failure to maintain minimum 24" clearances from combustible materials may create a fire hazard that may result in property damage or serious personal injury.

1. Slide Grill in Place

Begin by sliding the grill into place, ensuring it aligns properly with the cut-out. The grill is designed with an internal built-in hanger lip located on the right, left, and back sides. This allows the grill to hang by the three supported edges, while the front control panel hangs down the front of the cut-out.

2. Electrical Connection

Connect the electrical supply to the grill. This outdoor cooking appliance is equipped with a three-prong (grounding) plug for protection against shock hazard and should be plugged directly into properly grounded three-prong outlets. The electrical connection to the grill is located behind the back left side corner. Double-check that the plug is tightly pushed into the plug sockets at the back of the grill. Lift any loose wire and attach it to the back wall, keeping it away from any potential water collection on the floor of the island interior.

3. Allow for Ventilation

Proper ventilation is critical to the safe and efficient operation of the grill. Ensure there is a minimum of 6 inches of clearance behind the grill to allow for proper airflow. The grill is engineered with special vents on the back of the unit, which allow for proper airflow out of the back of the grill. Push the grill all the way into the cut-out, so that there are no gaps present between the grill and the inside of the island frame. Ensure that the grill control panel is flush against the island wall. Be sure to additionally have a minimum of Two-Vents placed in a High Position on the island wall, as to allow High-Heat Air-Circulation for within the island construction.

4. Familiarize Yourself with the Grill

Read all the instruction manual guides and information to familiarize yourself with the grill. Turn the pellet grill on by pressing the round button just below the control panel on the left-hand side. Get to know the digital control panel, see the three modes, SMOKE, GRILL and SEAR. The temperature gauge is in the center top, while the desired temperature is in the center bottom. On the right side are the three prongs with individual temperature readouts, connect the prongs at the bottom of control panel, with the three adjacent plugholes. Familiarizing yourself with the grill will help you to understand how to properly operate the grill and ensure that you get the most out of your outdoor cooking experience.

5. Add Pellets

Fill the hopper with wood pellets of your choice. Make sure to use only high-quality pellets designed for use in pellet grills, as lower quality pellets can cause issues with the grill's performance. We recommend B&B Wood Pellets – see www.bbcharcoal.com.

1. Grill Preparation

Proper Grill Maintenance needs to be part of your annual care of the Pellet Grill, the following solutions help ensure your grill will last for your lifetime and beyond. First, make sure that your grill is off, and the grates are cold. Wash all surfaces of Pellet Grill Before using the grill, wash all surfaces with warm soapy water and a wet sponge. This helps to remove debris off the surface which may otherwise cause rust staining. Dry with a soft towel.

2. Seasoning your Grill

You'll need spray bottles of high-heat cooking oil, such as vegetable oil, canola oil, or peanut oil. Any cooking oil with a high smoke point will work well for grilling.

The first thing you want to do is spray the inside of your grill, paying special attention to any stainless-steel grates and emitter plates. You'll also want to put a thin layer of oil on all inside surfaces of your grill. Remove the inside parts of the grill to make sure you can get to all the surfaces.

3. Turn on the Grill – See Grill Startup Page 17

Next, turn up the heat to high and let the grill get hot. The oil will seep into the pores of the steel and bake in, harden, and create a smooth nonstick coating. Let it burn and smoke and work its high heat magic for a good 30 to 40 minutes.

Seasoning your grill has three benefits: easier cooking and cleaning, better flavor, and extended grill life. Firstly, the oil used during seasoning protects the grates from rust and creates a non-stick surface, making cleaning easier. Secondly, the juices and fats from food vaporize during grilling, creating a signature flavor that improves over time. Lastly, seasoning helps to prevent rust-staining and gives you years of top-notch, non-stick, easy-care grilling. It's recommended to season your new grill right after getting it, and then once a year.

Building & Maintaining the Fire:

Building and maintaining the fire in a built-in Pellet Grill requires careful attention to the following recommendations:

1. Use high-quality, all-natural wood pellets that are designed for use in pellet grills. Avoid using fuel with additives or other materials that can damage the grill or affect the flavor of your food. We recommend B&B Wood Pellets – see www.bbcharcoal.com.
2. Follow all instructions for loading the hopper with pellets, and avoid overfilling the hopper, which can cause the pellets to jam and prevent proper combustion.
3. Start the grill according to the Grill Startup Guide in the Manual and allow it to heat up to the desired temperature before adding food.
4. Monitor the temperature of the grill closely and make any necessary adjustments to maintain a consistent heat. Avoid over-firing the grill, as this can cause damage to the grill and affect the quality of your food.
5. Regularly clean the burn grate and hopper to remove any debris or blockages that could affect the performance of the grill.
6. It is important to follow these recommendations carefully to ensure the safe and effective operation of your built-in electric pellet grill. Over-firing the grill, or exposing it to excessively high temperatures, can cause damage to the grill and increase the risk of fire.
7. To avoid over-firing the grill, it is important to follow the instructions set forth in this manual carefully, and to avoid making any modifications to the grill that could affect its performance. Always use the recommended fuel and avoid overfilling the hopper or allowing the grill to heat up excessively before adding food.

By following these recommendations and warnings, you can help to ensure a safe and enjoyable cooking experience with your built-in Pellet Grill.



CAUTION: Never use gasoline, gasoline-type lantern fuel, kerosene, charcoal lighter fluid, or similar liquids to start or “freshen up” a fire in this appliance. Keep all such liquids well away from the appliance when in use.

Operation of the Grill:

Operating and using electrical assemblies for a built-in pellet grill requires careful attention to the following technical guidelines:

- Ensure that the electrical supply to the grill is properly installed and grounded according to local electrical codes and manufacturer's instructions. Always use a properly grounded electrical outlet and avoid using extension cords or other devices that may cause power fluctuations or electrical hazards.
- Familiarize yourself with the control panel and user interface of the grill. The control panel should allow you to adjust the temperature, set cooking times, and monitor the status of the grill. Follow the manufacturer's instructions carefully when using the control panel and make any necessary adjustments to maintain the desired temperature and cooking conditions.



ATTENTION: Use Only Wood Pellet Fuel Specified by The Manufacturer – B&B Wood Pellets. Do Not Use Pellet Fuel Labeled as Having Additives. Using pellet fuel labeled as having additives or other materials can damage the grill or affect the flavor of your food and should be avoided.

Pellet Name & Grade Requirement

The grade designation for wood pellets used in pellet grills can vary depending on the manufacturer, but the most common grades are "Premium" or "Food-Grade". These designations indicate that the pellets are made from high-quality, food-safe materials that are free from chemicals, additives, or other contaminants that could potentially harm the food being cooked on the grill. We recommend B&B Wood Pellets – see www.bbcharcoal.com.

Mean Pellet Heating Value

The mean heating value in BTU (British Thermal Units) per pound of wood pellets the pellet grill can vary depending on the type and quality of the pellets. However, on average, wood pellets used in pellet grills have a heating value of around 8000 to 8500 BTU per pound. This means that each pound of wood pellets can produce approximately 8000 to 8500 BTUs of heat energy when burned. It is important to note that the heating value of wood pellets can also be affected by factors such as moisture content, density, and ash content, so it's essential to use high-quality pellets that are specifically designed for use in pellet grills to ensure optimal performance and heat output.

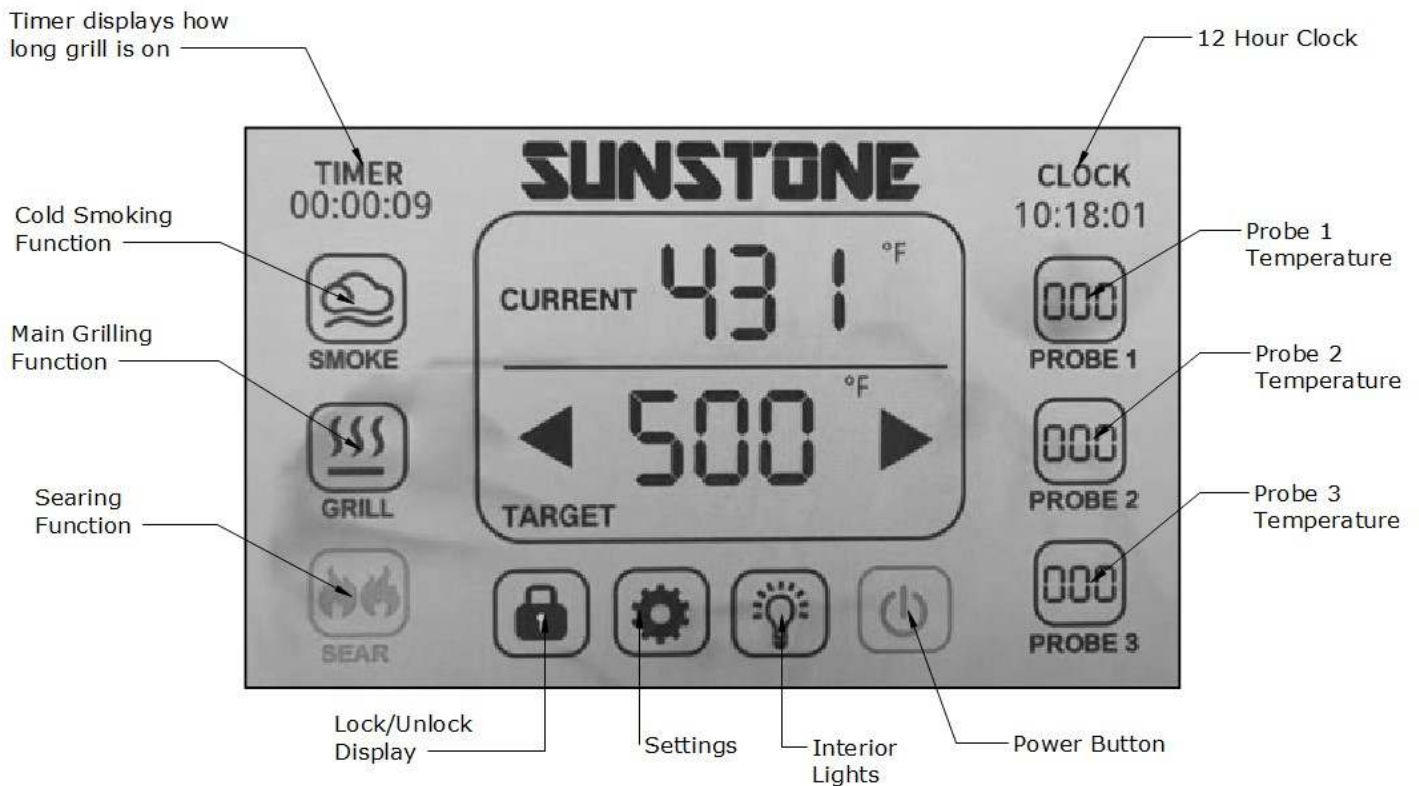

1. Plug the power cord into a Grounded power source (120 Volt Required). Initial set up of your pellet grill, Press setting icon to set time, temperature C° or F°, Bluetooth and hit save. Lock Setting, Push lock icon, Red=Locked, Green=Unlock. *(Bluetooth connectivity mode is currently in development)*
2. Open the Main Hood. Check the burn grate to ensure there is no obstruction for proper ignition. Open the left hopper lid. Ensure there are no foreign objects in the hopper or auger feed system. Fill the hopper with dry, all natural barbecue hardwood pellets.
3. With the Hood Closed, turn the unit on by pressing the Power Button located at the base of the control box, display with activate within 5 seconds.
4. Turn on power button on display panel, chose either Smoke, Grill or Sear. You may use the Smoke function in conjunction with either Grill or Sear. You can manually adjust temperature by pushing Arrow button on target. Pellet loader will start feeding grill pellets, the main ignition system will start working, it takes around 3 minute to ignite, green lights show in working mode.

SMOKE - Cold Smoking

Cold smoking, open the small cover to expose the cold smoker box in front, pull the feeder tube out and add pellets then slide the tube back into compartment and close the cold smoker box cover. Turn on display panel, chose SMOKE setting. The temperature will not rise with this setting since the pellets are burned in separate internal compartment. As Smoke develops this is pushed up and through a pipe where it is cooled with a fan blower. At this point it now will enter the main grilling



GRILL - Grilling

The Grilling function is the most common function to use, with temperature ranges between 200 to 500 degrees. With the grilling function you can cook most all variations and you can smoke with the heated flame. You can even use two types of natural hardwood pellets, one for the Cold Smoker and one for the Grilling.



ATTENTION: Should a grease fire occur, turn the grill off and leave the lid closed until the fire is out. Do not unplug the power cord. Do not throw water on the unit. Do not try to smother the fire. Highly recommend the use of a fire extinguisher to keep on site. If an uncontrolled fire does occur, call the Fire Department.

SEAR - Searing

Sear sets the grill to very high temperatures to sear the outside of your food sealing in the all the flavor while quickening the grilling. The searing function allows between 500-700 degrees, excellent searing temperature.



Ash Tray

Never use the grill if the Ash Tray is not installed or fully closed. Ashes should be placed in a metal container with a tight-fitting lid. The container must be placed on a non-combustible surface well away from all other combustible materials. Ashes are to remain in the container until fully cooled, then disposed of properly. It is recommended to clean the pellet burning chamber periodically.

Grill Operation

Your Wood Fired Pellet Grill and Smoker has been designed and engineered to produce smoke that infuses your food with a smoky flavor. The firepot requires air for efficient combustion. This fresh air is pulled through a vent in the front of your grill and the intense hot air and smoke produced by the pellets is expelled through a vent in the rear. If you are using your grill in windy conditions, the wind can disrupt this important airflow.

Indirect Cooking

Indirect cooking is the process of cooking your food without the heat source directly under your food. You can sear meats over a high flame on one side of the grill while slow cooking on the other side of the grill. It is like cooking in an oven and is generally used for larger cuts of meats but can also be used for cooking foods that are prone to flare ups. Indirect Cooking will result in tender foods every time you grill.

Direct Cooking

Direct cooking is the process of cooking your food directly over hot coals. This method is also called Searing or Grilling. Direct cooking is recommended for most grilling applications, and the best place to perform Direct Cooking is in the place where the cooking surface is the hottest. This type of cooking locks in flavor and juices while allowing the outer surface to absorb smoke and food aroma that is produced as grease and drippings are vaporized by the coals. The result is a crisp, flavorful outside with a tender, juicy inside.



ATTENTION: If the grill is set to a high heat setting and the hood is closed, wind can prevent the hot air from being expelled through the rear vent – forcing heat to the front of the grill. This heat can make the hood handle and front panel extremely hot. In some cases, this heat can damage important components.



ATTENTION: Ashes should be placed in a metal container with a tight-fitting lid. The closed container of ashes should be placed on a noncombustible floor or on the ground, well away from all combustible materials, pending final disposal. If the ashes are disposed of by burial in soil or otherwise locally dispersed, they should be retained in the closed container until all cinders have thoroughly cooled.

Use only Specified Accessories

Do not use accessories not specified for use with this appliance. Using pellet grill accessories that are not specified for use with the pellet grill can be dangerous and may result in several potential hazards. Some of the dangers of using incompatible pellet grill accessories include:

- **Fire hazard:** Using incompatible accessories can result in fire hazards. For example, if you use a non-pellet grill rated griddle, it may not be able to withstand the high temperatures generated by the pellet grill, which could result in a fire.
- **Damage to the grill:** Using the wrong accessories can also damage the grill. For instance, using a metal scraper or brush can scratch and damage the stainless-steel brushed finish.
- **Health hazards:** Using non-compatible accessories may also pose health hazards. For example, if you use a chemical cleaner on a grill, it may contaminate the food and harm your health.
- **Invalidating warranties:** Using incompatible accessories can also void the warranty of the pellet grill. If the grill is damaged because of using the wrong accessories, this may Void your manufacturer warranty.

Poison Prevention

Follow these guidelines to prevent this colorless, odorless gas from poisoning you, your family, or others.

- Know the symptoms of carbon monoxide poisoning: headache, dizziness, weakness, nausea, vomiting, sleepiness, and confusion. Carbon monoxide reduces the blood's ability to carry oxygen. Low blood oxygen levels can result in loss of consciousness and death.
- See a doctor if you or others develop cold or flu-like symptoms while cooking or in the vicinity of this appliance. Carbon monoxide poisoning, which can easily be mistaken for a cold or flu, is often detected too late.
- Alcohol consumption and drug use increase the effects of carbon monoxide poisoning.

Carbon monoxide is especially toxic to mother and child during pregnancy, infants, the elderly, smokers, and people with blood or circulatory system problems, such as anemia, or heart disease.



ATTENTION: Major causes of appliance fires are a result of poor maintenance and a failure to maintain required clearance to combustible materials. It is important that this grill be installed and used in accordance with this manual.

Q. Either One or Both Interior Lights do not work?

A. Most often the interior Halogen Lights will burn out one at a time, if both are out at the same time, you could have a connection issue. If all the Lights do not work, then it is either unplugged or the Transformer has malfunctioned. Each Halogen light can be replaced by unscrewing a single screw per light located on left sides of light cover, the entire light box needs to be removed, and there are two small black wires hard plugged into back of light. Use a pair of pliers to remove these, replacing to new Halogen Light box, again use a pair of pliers to push each wire into each socket of light box, Test light is working before inserting back into hole and again tightening the small screw on left outer side.

Q. What is Cold Smoking, and should you use it?

A. Cold smoking is about infusing immense flavor using cold smoke into the food. It is not all food types that can be cold smoked, but most can. The important thing is to make sure that you use the proper tools and that you think about why you are smoking the food. It also helps to have a clear end goal.

Q. What is the difference between Cold Smoking and Hot Smoking?

A. The difference between cold smoking and traditional smoking is the temperature of the grill. If the grill is 150F degrees or less it is considered cold smoking. Traditional smoking normally is from 200F degrees and up.

Q. How much does the hopper hold?

A. About 20LBS of Natural Barbeque Wood Pellets.

Q. What is my temp range?

A. Ambient Temperature for Cold Smoking, Grilling is 200-500 degrees, and Searing is 500 to 700 degrees.

Error Codes

If the grill is compromised in any way, usually a error code will display in place of the Temperature Location. They are designated by an “E” for error following by a numerical value. Refer to this page in diagnosing any issue which may arise in your grills operating, call our technical team for assistance 888-934-9449.



Grill will enter shut-off mode once errors E01 to E04 are detected, the grill cannot be operated in fail safe mode. Grill will automatically restart once error is cleared, and alarm dismissed. Error E01 to E04 will be shown on display panel in place of current temperature.

E01 – UNABLE TO LIGHT

If you see error code E01 on the screen, this means the grill is unable to light the pellets. The grill will automatically attempt to light the pellets for 6 times, so long as the temperature is below 160F. If still unsuccessful in lighting the pellets turn the grill off and back on using the main power button.

E02 – UNABLE TO READ TEMPERATURE

The grill temperature is greater than 700°F, and the high temperature reports an error.

E03 – TEMPERATURE PROBE NOT WORKING

Grill temperature sensor assembly short circuit.

E04 – BROKEN TEMPERATURE PROBE

After the ignition mode, the furnace temperature is less than 135°F.

When any error status is detected and automatically enters the shutdown state. Fault alarm numbers that are displayed at the actual temperature location. After displaying the fault status, all operations are invalid. Only after the grill is connected and turned on, can the alarm be cleared and transferred to the normal boot procedure.

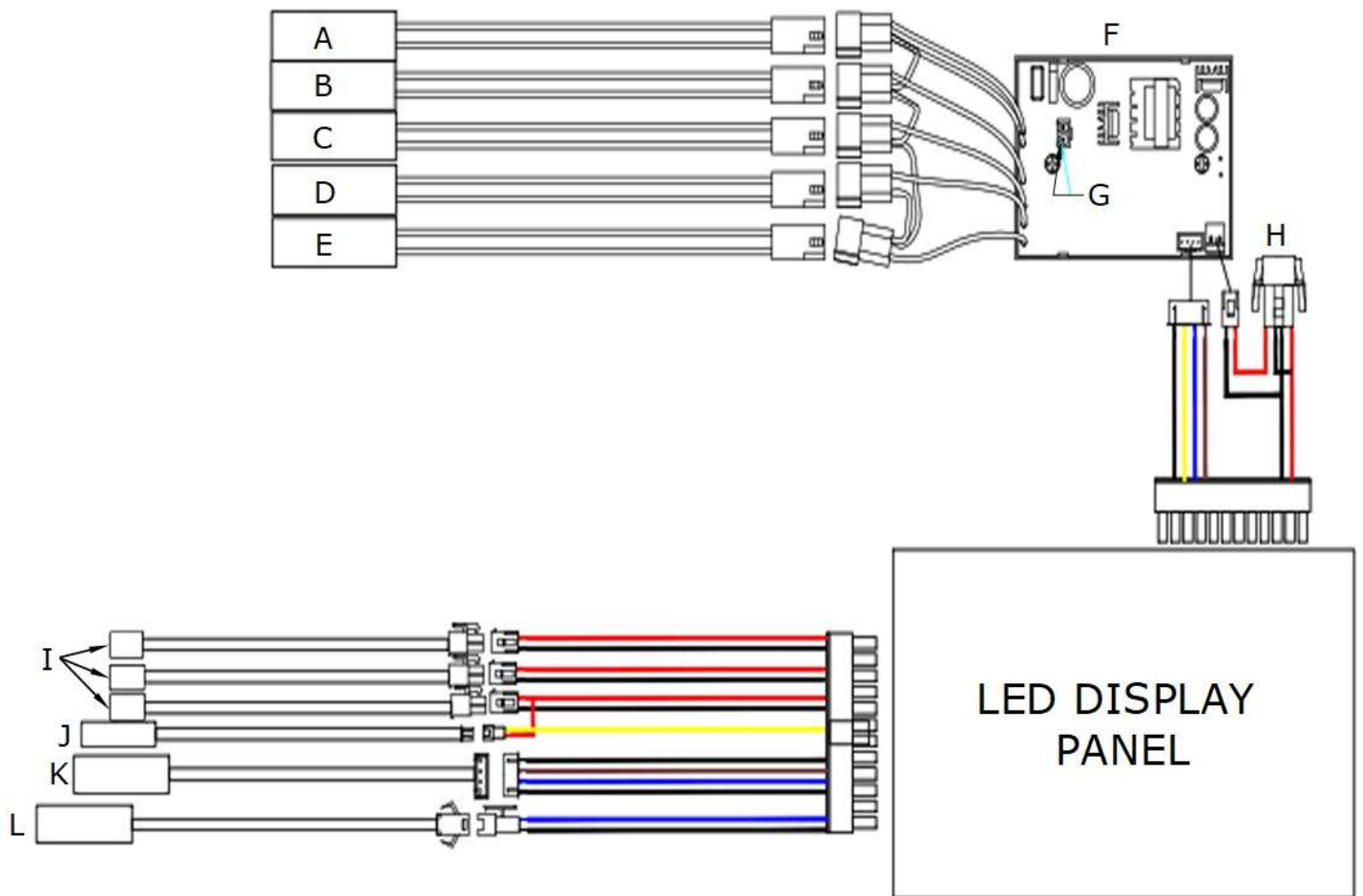

(A) Power Outlet (Black/White/Green)
(B) Ignition Stick (Purple/White)
(C) Ignition Stick (Purple/White)
(D) Fan (Orange/White)
(E) Hopper Motor (Red/White)
(F) Motherboard

(G) Fuse Connector
(H) 16mm Switch
(I) Lights
(J) 12 Volt Small Fan
(K) Food Probe Meter
(L) Probe Meter



VOLTAGE: Use only extension cords approved for outdoor use marked with W-A and rated for the power of this appliance.



LIVE CIRCUIT: Use only with a Ground-Fault Circuit Interrupter - GFCI protected Outlet with this grill.



ATTENTION: The Pellet Grill must be installed according to the product manual. If your grill installation does not meet the Basic Setup Instructions **ALL WARRANTIES MAY BE VOID.**

SUNSTONE SERIES 40" PELLET GRILL WARRANTY

*****All Warranties Start from the Date of Purchase*****

LIMITED LIFETIME WARRANTY

Sunstone Stainless Rod Cooking Grids and Stainless-Steel Housings (including liners, frames, firebox and hood and all exterior grill faces) are warranted for as long as you own the Sunstone Barbecue Grill against all factory defects. This warranty does not cover against consumer usage wear and tear from using the grill as all grilling methods will erode the 304 Stainless Steel Materials. Owner must pay for any shipping and handling charges.

LIMITED THREE-YEAR WARRANTY: *Sunstone warrants the stainless-steel cooking grates, burner pot and drip pans to be free from defects in materials and workmanship under normal residential use for a period of five years from the original date of purchase.*

LIMITED ONE-YEAR WARRANTY: *Sunstone warrants all electrical parts and components to be free from defects in materials and workmanship under normal residential use for a period of one year from the original date of purchase. Including the Main Control Panel, Lights, gear motors, Starter Ignitions and any other related part.*

For all the above warranties, the actual parts will be repaired or replaced, free of charge, with the owner paying for all other costs including labor, shipping, and handling.

NINETY (90) DAY RESIDENTIAL PLUS WARRANTY: *This warranty applies to applications where use of the product extends beyond normal residential use such as bed and breakfast inn and private clubs or apartment complexes. The actual part will be repaired or replaced, free of charge, with the owner paying for all other costs including service tech labor, shipping, and handling. This warranty excludes all commercial locations such as restaurants and food service locations.*

LIMITATIONS & EXCLUSIONS

1. *SUNSTONE warranty applies only to the original purchaser and may not be transferred.*
2. *SUNSTONE warranty is in lieu of all other warranties expressed or implied and all other obligations or liabilities related to the sale or use of its grill products.*
3. *SUNSTONE warranty shall not apply, and SUNSTONE is not responsible for damage resulting from misuse, abuse, alteration of or tampering with the appliance, accident, hostile environment, flare-up fires, improper installation, or installation not in accordance with the instructions contained in the User Manual, or the local codes.*
4. *SUNSTONE is not responsible for warping of component parts due to overheating or using in a way not in line with the product manual.*
5. *SUNSTONE shall not be liable for incidental, consequential, special, or contingent damages resulting from its breach of this written warranty or any implied warranty.*
6. *Some states do not allow limitations on how long an implied warranty lasts, or the exclusions of or limitations on Consequential damages. This warranty gives you specific legal rights and you may have other rights, which vary from state to state.*
7. *No one has the authority to add to or vary SUNSTONE warranty, or to create for SUNSTONE any other obligation or liability in connection with the sale or use of its products.*
8. *SUNSTONE DOES NOT COVER FOR WARPING OF STEEL DRAWER, GRATES, OR ANY OTHER COMPONENT FROM THE RESULT OF MISUSE OR OVERHEATING OF COMPONENTS.*

WHAT IS NOT COVERED. & INTERNET PURCHASE DISCLAIMER

SUNSTONE shall not be responsible for and shall not pay for the following Installation or start-up.

1. Service by an unauthorized service provider and the cost of a service tech of any warranted parts.
2. Damage or repair due to service by an unauthorized service provider or use of unauthorized parts.
3. Damage caused by accidents, abuse, alteration, misuse, installation that is not in accordance with the instructions contained in the User Manual, or local codes.
4. Shipping and handling costs, export duties, or installation cost.
5. The cost-of-service calls to diagnose trouble, or Removal or re-installation cost.

This warranty applies to the original purchaser with invoice or proof of purchase and covers Sunstone products intended for personal, family or household usage only. It does not apply to surface rust, corrosion, oxidation, or discoloration, which may occur due to moisture or overheating, unless the affected component becomes inoperable. This warranty does not cover parts becoming defective by misuse, accidental damage, improper handling and/or installation. It does not cover labor or labor related charges. It specifically excludes liability for indirect, incidental, or consequential damages. Some states do not allow the exclusion or limitation of incidental or consequential damages, so the above exclusion or limitation may not apply to you. This warranty gives you specified legal rights, and you may have other rights which may vary from state to state. For additional information regarding this warranty, or information on how to place a warranty claim, contact your authorized Sunstone dealer.