

ARUBA SERIES ODK COMPONENTS

PRODUCT

36" Double Access
Vented Door

Item No. ARU-VDD36

DESCRIPTION

36" Aruba Series Vented Double Door, works best w/appliance between 34" to 40" Width & Singular Vent Location

PRODUCT DIMENSIONS

Product Size: 36" WIDTH x 20-1/2" HEIGHT x 1-3/4" DEPTH
Cut-Out Size: 34-1/8" WIDTH x 19" HEIGHT x 2-1/4" DEPTH

SPECIFICATIONS

304 Stainless Steel
Construction Frame, Doors

WARRANTY

3 YEARS STRUCTURE
WARRANTY AGAINST
MANUFACTURE DEFECTS

Product Dimensions

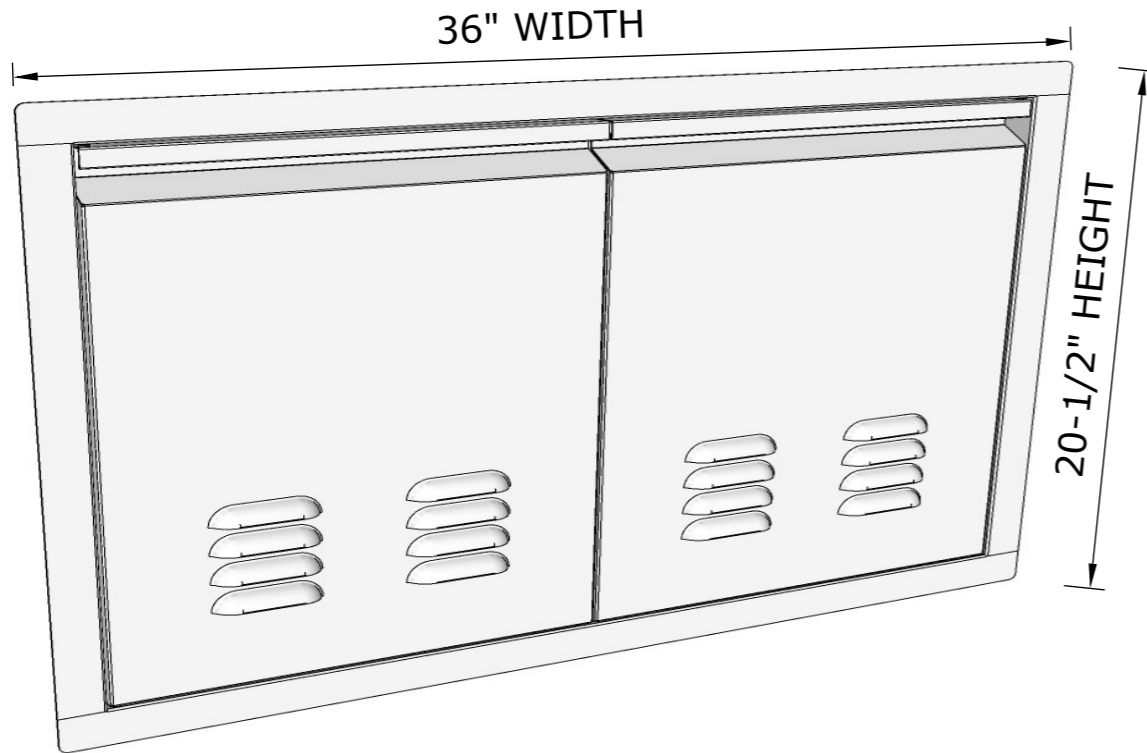

Product Features

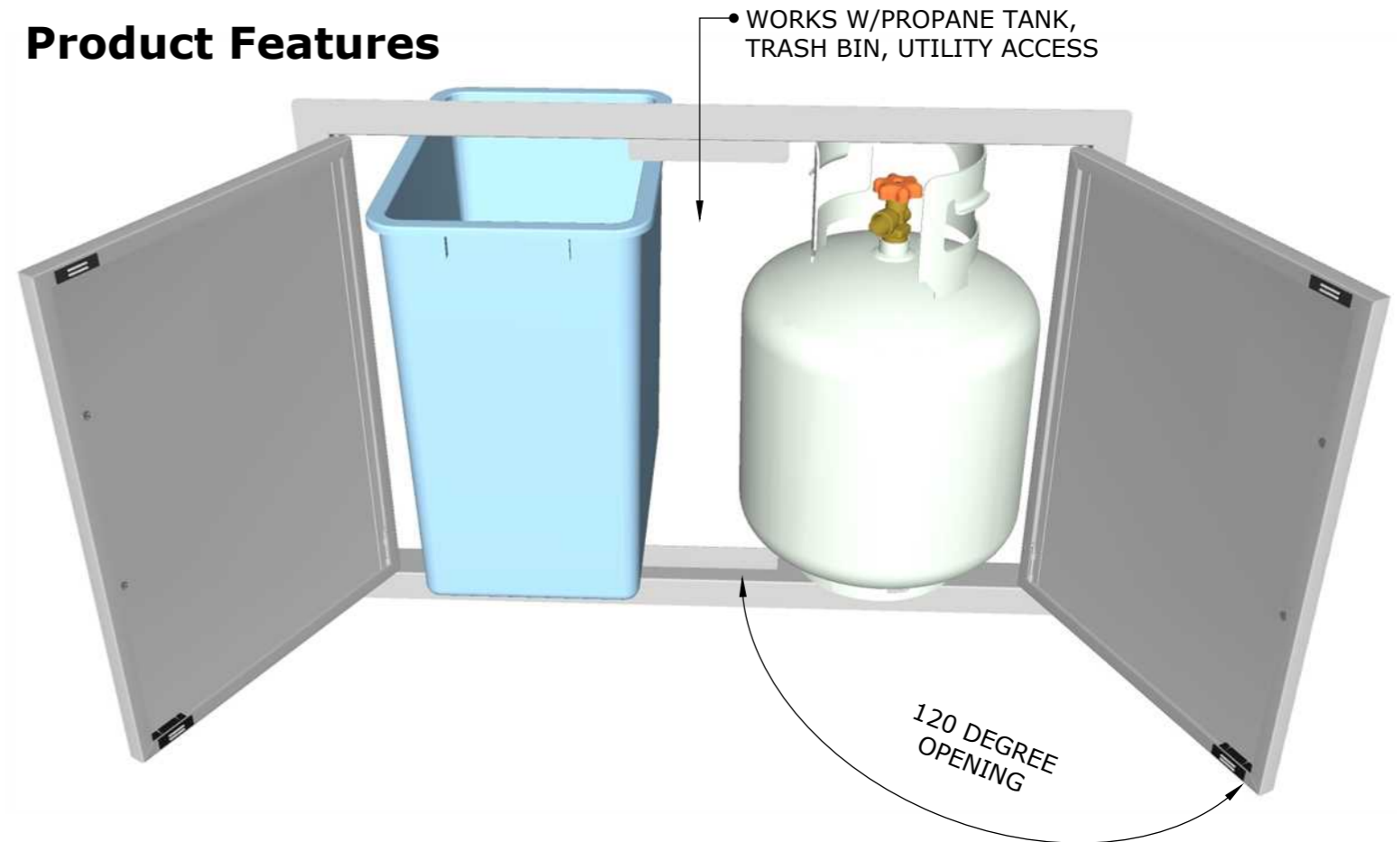

ISLAND WALL CUT-OUT SIZE:
34-1/8" WIDTH x 19" HEIGHT x 2-1/4" Depth

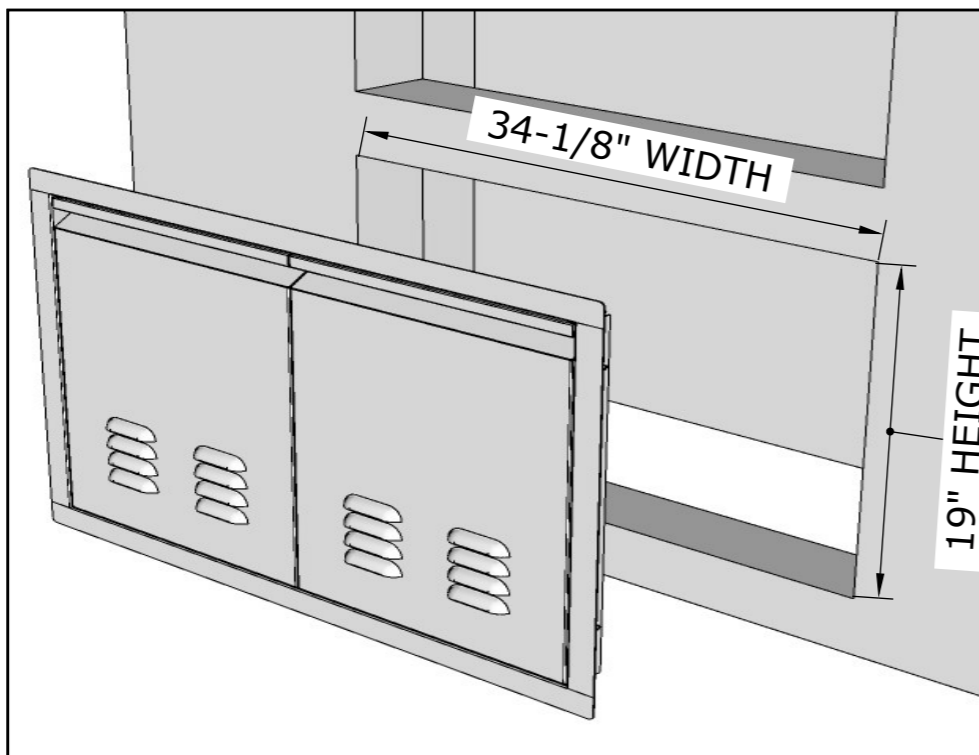

OPEN SLOTS ALLOW
FOR EASY INSTALLATION

HAVE COMPONENT ON
SITE BEFORE MAKING
ISLAND CUTS, CONFIRM
ALL DIMENSIONS
BEFORE CUTTING INTO
ISLAND WALL

MOUNT TO INTERIOR
ISLAND CUT-OUT EDGE
USING SCREW
CONSISTENT WITH YOUR
INSTALLATION TYPE.
CONCRETE, MASONRY,
WOOD, METAL ALL USE
DIFFERENT SCREW
TYPES (HARDWARE NOT
INCLUDED)

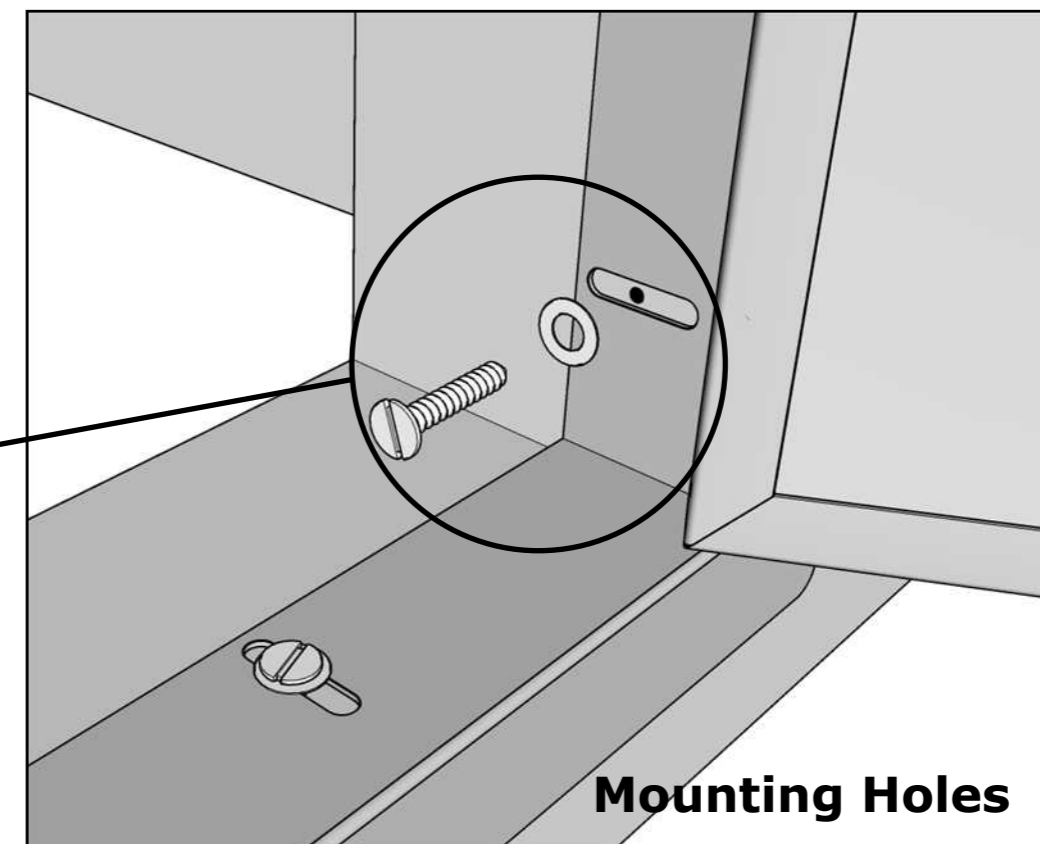

Product Cut-Out